



Winstar Display Co., LTD 華凌光電股份有限公司



住址: 407 台中市中清路 163 號
No.163 Chung Ching RD.,
Taichune, Taiwan, R.O.C

WEB: <http://www.winstar.com.tw>
E-mail: winstar@winstar.com.tw
Tel:886-4-24262208 Fax : 886-4-24262207

SPECIFICATION

CUSTOMER : _____

MODULE NO.: WG12232C-TMI-T#A

APPROVED BY: (FOR CUSTOMER USE ONLY)	PCB VERSION:	DATA:

SALES BY	APPROVED BY	CHECKED BY	PREPARED BY
ISSUED DATE:			



MODLE NO :

RECORDS OF REVISION

DOC. FIRST ISSUE

VERSION	DATE	REVISED PAGE NO.	SUMMARY
0	2006.6.12		First issue

Contents

- 1.Module Classification Information
- 2.Precautions in use of LCD Modules
- 3.General Specification
- 4.Absolute Maximum Ratings
- 5.Electrical Characteristics
- 6.Optical Characteristics
- 7.Interface Description
- 8.Contour Drawing & Block Diagram
- 9.Function Description
- 10.Commands Description
- 11.Timing Characteristics
- 12.Reliability
- 13.Backlight Information
14. Inspection specification
15. Material List of Components for RoHs

1.Module Classification Information

W G 1 2 2 3 2 C - T M I - T#A

Brand : WINSTAR DISPLAY CORPORATION

Display Type : H→Character Type, G→Graphic Type

Display Font : 122 x 32 dots

Model serials no.

Backlight Type : N→Without backlight T→LED, White

B→EL, Blue green A→LED, Amber

D→EL, Green R→LED, Red

W→EL, White O→LED, Orange

F→CCFL, White G→LED, Green

Y→LED, Yellow Green

LCD Mode : B→TN Positive, Gray T→FSTN Negative

N→TN Negative,

G→STN Positive, Gray

Y→STN Positive, Yellow Green

M→STN Negative, Blue

F→FSTN Positive

LCD Polarizer Type/ Temperature A→Reflective, N.T, 6:00 H→Transflective, W.T,6:00

range/ View
direction

D→Reflective, N.T, 12:00 K→Transflective, W.T,12:00

G→Reflective, W. T, 6:00 C→Transmissive, N.T,6:00

J→Reflective, W. T, 12:00 F→Transmissive, N.T,12:00

B→Transflective, N.T,6:00 I→Transmissive, W. T, 6:00

E→Transflective, N.T.12:00 L→Transmissive, W.T,12:00

Special Code

T :Temperature Compensation generator and Negative Voltage on board

A: Avant IC

#:Fit in with the ROHS Directions and regulations

2.Precautions in use of LCD Modules

- (1)Avoid applying excessive shocks to the module or making any alterations or modifications to it.
- (2)Don't make extra holes on the printed circuit board, modify its shape or change the components of LCD module.
- (3)Don't disassemble the LCM.
- (4)Don't operate it above the absolute maximum rating.
- (5)Don't drop, bend or twist LCM.
- (6)Soldering: only to the I/O terminals.
- (7)Storage: please storage in anti-static electricity container and clean environment.

3.General Specification

Item	Dimension	Unit
Number of Characters	122 x 32 dots	-
Module dimension	84.0 x 44.0 x 14.2(MAX)	mm
View area	60.0 x 18.0	mm
Active area	53.64 x 15.64	mm
Dot size	0.4 x 0.45	mm
Dot pitch	0.44 x 0.49	mm
LCD type	STN Negative, Transmissive, Blue	
Duty	1/32	
View direction	6 o'clock	
Backlight Type	LED White	

4. Absolute Maximum Ratings

Item	Symbol	Min	Typ	Max	Unit
Operating Temperature	T_{OP}	-20	-	+70	°C
Storage Temperature	T_{ST}	-30	-	+80	°C
Input Voltage	V_I	0	-	V_{DD}	V
Supply Voltage For Logic	V_{DD}	0	-	6.7	V
Supply Voltage For LCD	$V_{DD}-V_{LCD}$	0	-	-10	V

Supply Voltage For LCD	V_{OUT}	-	-	-5	V
------------------------	-----------	---	---	----	---

5. Electrical Characteristics

Item	Symbol	Condition	Min	Typ	Max	Unit
Supply Voltage For Logic	$V_{DD}-V_{SS}$	-	4.5	5.0	5.5	V
Supply Voltage For LCD	$V_{DD}-V_0$	Ta=-20°C	-	-	5.5	V
		Ta=25°C	-	4.5	-	V
		Ta=+70°C	3.9	-	-	V
Input High Volt.	V_{IH}	-	2.0	-	V_{DD}	V
Input Low Volt.	V_{IL}	-	0	-	0.8	V
Output High Volt.	V_{OH}	-	2.7	-	V_{DD}	V
Output Low Volt.	V_{OL}	-	0	-	0.4	V
Supply Current	I_{DD}	-	-	5.0	-	mA

6. Optical Characteristics

Item	Symbol	Condition	Min	Typ	Max	Unit
View Angle	(V) θ	CR \geq 2	20	-	40	deg

	(H) ϕ	$CR \geq 2$	-30	-	30	deg
Contrast Ratio	CR	-		3	-	-
Response Time	T rise	-	-	100	150	ms
	T fall	-	-	100	150	ms

Definition of Operation Voltage (Vop)

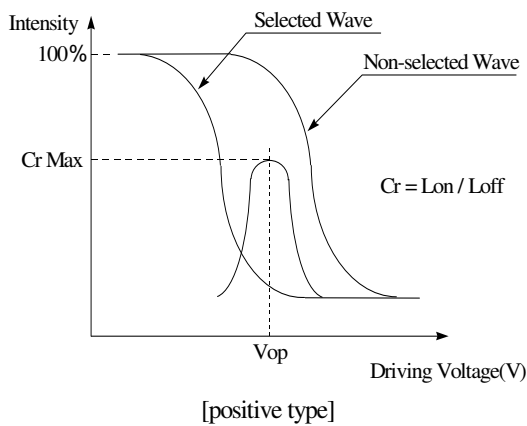

Definition of Response Time (Tr, Tf)

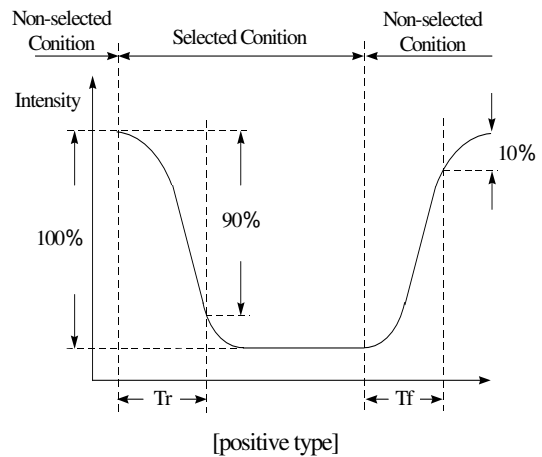

Conditions :

Operating Voltage : Vop Viewing Angle(θ , ϕ) : 0° , 0°

Frame Frequency : 64 HZ Driving Waveform : 1/N duty , 1/a bias

Definition of viewing angle($CR \geq 2$)

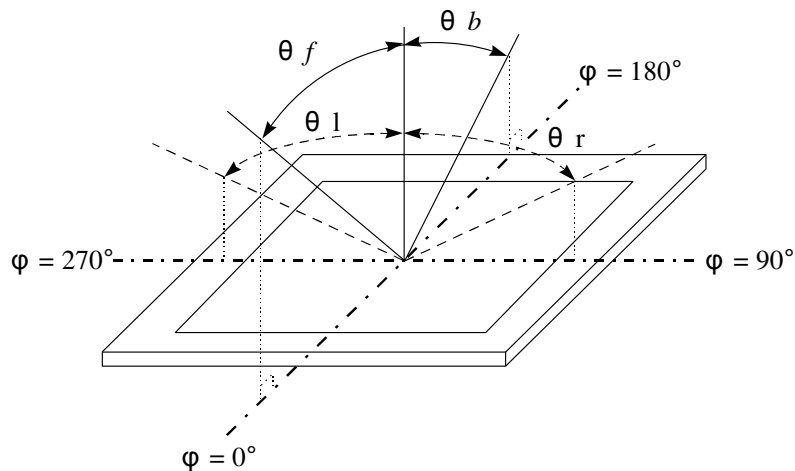

7.Interface Description

Pin No.	Symbol	Level	Description
1	V _{ss}	0V	Ground
2	V _{dd}	5V	Power supply for logic
3	V _o	(Variable)	Operating voltage for LCD
4	A0	H/L	H : Data L : Instruction
5	CS1	H/L	Chip select signal for IC1
6	CS2	H/L	Chip select signal for IC2
7	CL	-	External clock 2KHz
8	E(/RD)	H/L	Enable Signal (/RD is for 80 series MPU read signal)
9	R/W (/WR)	H/L	H : Read ; L : Write (/WR is for 80 series MPU write signal)
10	DB0	H/L	Data bus line
11	DB1	H/L	Data bus line
12	DB2	H/L	Data bus line
13	DB3	H/L	Data bus line
14	DB4	H/L	Data bus line
15	DB5	H/L	Data bus line
16	DB6	H/L	Data bus line
17	DB7	H/L	Data bus line
18	RES	H/L	68-series MPU when H→L the LCM is reset. 80- series MPU when L→H the LCM is reset. High level:68-series MPU interface Low level:80-series MPU interface
19	A	-	Power Supply for LED backlighth (+)
20	K	-	Power Supply for LED backlighth (-)

8. Contour Drawing & Block Diagram

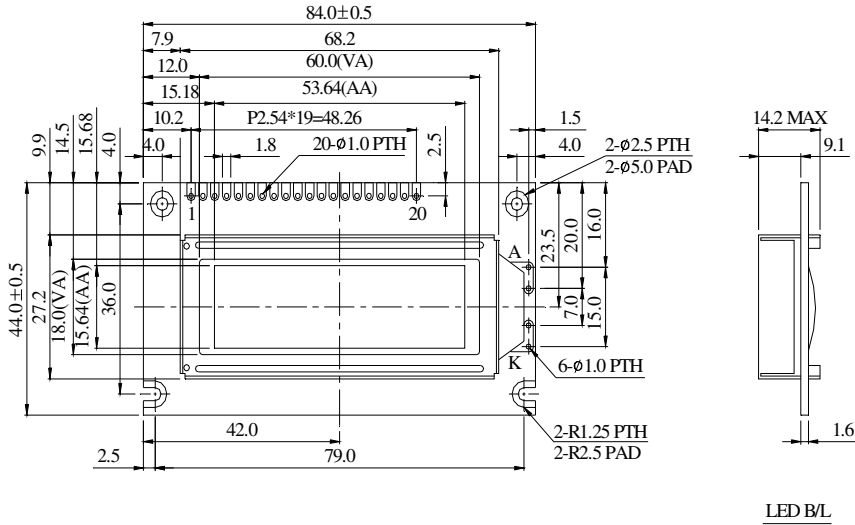

PIN NO.	SYMBOL
1	Vss
2	Vdd
3	Vo
4	A0
5	CS1
6	CS2
7	CL
8	E
9	R/W
10	DB0
11	DB1
12	DB2
13	DB3
14	DB4
15	DB5
16	DB6
17	DB7
18	RES
19	A
20	K

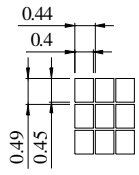

DOT SIZE

The non-specified tolerance of dimension is $\pm 0.3\text{mm}$.

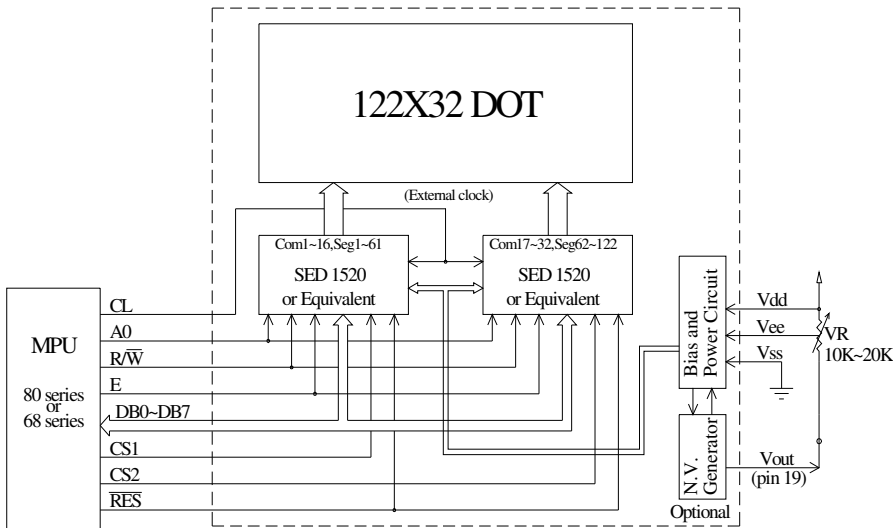

External contrast adjustment.

LED B/L Drive Method

1. Drive from A, K

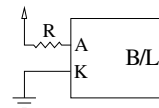

2. Drive from pin19, pin20

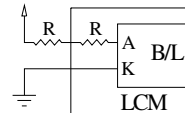

(Will never get Vout from pin19)

3. Drive from Vdd, Vss

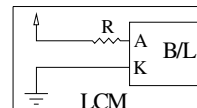

(Contrast performance may go down.)

Recommended Value

$V_{LED} = 4.2\text{V}$, $I_{LED} = 120\text{mA}$

$R = 6.7\Omega$ (1/2 Watt)

9. Function Description

Block Diagram

This 122×32 dots LCD Module built in two SED 1520 LSI controller.

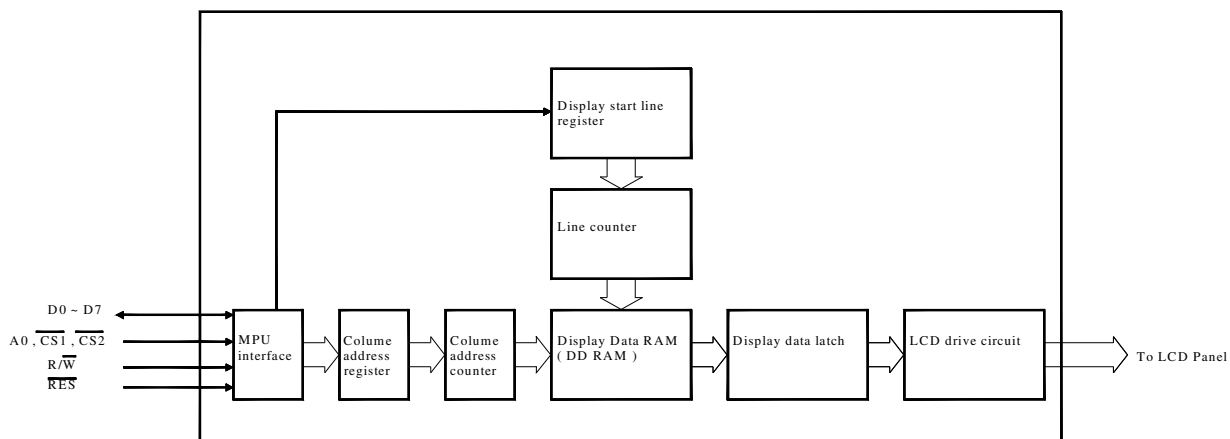

MPU interface

The SED 1520 controller transfers data via 8-bit bidirectional data buses (D0 to D7), it can fit any MPU if it corresponds to SED 1520 Read and Write Timing Characteristics.

Data transfer

The SED1520 driver uses the A0, E and R/W signals to transfer data between the system MPU and internal registers, The combinations used are given in the table below.

A0	R/W	Function
1	1	Read display data
1	0	Write display data
0	1	Read status
0	0	Write to internal register (command)

Busy flag

When the Busy flag is logical 1, the SED1520 series is executing its internal operations. Any

command other than Status Read is rejected during this time. The Busy flag is output at pin D7 by the Status Read command. If an appropriate cycle time (t_{CYC}) is given, this flag needs not be checked at the beginning of each command and, therefore, the MPU processing capacity can greatly be enhanced.

Display Start Line and Line Count Registers

The contents of this register form a pointer to a line of data in display data RAM corresponding to the first line of the display (COM0), and are set by the Display Start Line command.

Column Address Counter

The column address counter is a 7-bit presentable counter that supplies the column address for MPU access to the display data RAM. See Figure 1. The counter is incremented by one every time the driver receives a Read or Write Display Data command. Addresses above 50H are invalid, and the counter will not increment past this value. The contents of the column address counter are set with the Set Column Address command.

Display Data RAM

The display data RAM stores the LCD display data, on a 1-bit per pixel basis. The relationship between display data, display address and the display is shown in Figure 1

Page Register

The page register is a 2-bit register that supplies the page address for MPU access to the display data RAM. See Figure 1. The contents of the page register are set by the Set Page Register command.

Figure 1.
Display Data RAM Address

Page address	DATA	Line address	Common output
D1,D2=0,0	D0	00H	COM0
	D1	01H	COM1
	D2	02H	COM2
	D3	03H	COM3
	D4	04H	COM4
	D5	05H	COM5
	D6	06H	COM6
	D7	07H	COM7
0,1	D0	08H	COM8
	D1	09H	COM9
	D2	0AH	COM10
	D3	0BH	COM11
	D4	0CH	COM12
	D5	0DH	COM13
	D6	0EH	COM14
	D7	0FH	COM15
1,0	D0	10H	COM16
	D1	11H	COM17
	D2	12H	COM18
	D3	13H	COM19
	D4	14H	COM20
	D5	15H	COM21
	D6	16H	COM22
	D7	17H	COM23
1,1	D0	18H	COM24
	D1	19H	COM25
	D2	1AH	COM26
	D3	1BH	COM27
	D4	1CH	COM28
	D5	1DH	COM29
	D6	1EH	COM30
	D7	1FH	COM31
ADC	D0=0	4FH	00H
	D0=1	4EH	01H
ADC	D0=0	4DH	02H
	D0=1	4CH	03H
ADC	D0=0	3BH	04H
	D0=1	3AH	05H
ADC	D0=0	3BH	06H
	D0=1	3AH	07H
ADC	D0=0	3BH	08H
	D0=1	3AH	09H
ADC	D0=0	3BH	0AH
	D0=1	3AH	0BH
ADC	D0=0	3BH	0CH
	D0=1	3AH	0DH
ADC	D0=0	3BH	0EH
	D0=1	3AH	0FH
ADC	D0=0	3BH	10H
	D0=1	3AH	11H
ADC	D0=0	3BH	12H
	D0=1	3AH	13H
ADC	D0=0	3BH	14H
	D0=1	3AH	15H
ADC	D0=0	3BH	16H
	D0=1	3AH	17H
ADC	D0=0	3BH	18H
	D0=1	3AH	19H
ADC	D0=0	3BH	1AH
	D0=1	3AH	1BH
ADC	D0=0	3BH	1CH
	D0=1	3AH	1DH
ADC	D0=0	3BH	1EH
	D0=1	3AH	1FH
ADC	D0=0	3BH	18H
	D0=1	3AH	19H
ADC	D0=0	3BH	1AH
	D0=1	3AH	1BH
ADC	D0=0	3BH	1CH
	D0=1	3AH	1DH
ADC	D0=0	3BH	1EH
	D0=1	3AH	1FH
ADC	D0=0	3BH	18H
	D0=1	3AH	19H
ADC	D0=0	3BH	1AH
	D0=1	3AH	1BH
ADC	D0=0	3BH	1CH
	D0=1	3AH	1DH
ADC	D0=0	3BH	1EH
	D0=1	3AH	1FH
ADC	D0=0	3BH	18H
	D0=1	3AH	19H
ADC	D0=0	3BH	1AH
	D0=1	3AH	1BH
ADC	D0=0	3BH	1CH
	D0=1	3AH	1DH
ADC	D0=0	3BH	1EH
	D0=1	3AH	1FH

10. Commands Descriptions

Summary

Command	Code											Function
	A0	RD	WR	D ₇	D ₆	D ₅	D ₄	D ₃	D ₂	D ₁	D ₀	
Display ON/OFF	0	1	0	1	0	1	0	1	1	1	0/1	Turns display on or off. 1:ON, 0:OFF
Display start line	0	1	0	1	1	0	Display start address (0 to 31)				Specifies RAM line corresponding to top line of display.	
Set page address	0	1	0	1	1	0	1	1	0	Page (0 to 3)		Sets display RAM page in page address register.
Set column (segment) address	0	1	0	0	Column address (0 to 79)							Sets display RAM column address in column address register.
Read status	0	0	1	Busy	ADC	ON/OFF	Reset	0	0	0	0	Reads the following status: BUSY 1:Busy 0:Ready ADC 1: CW output 0: CCW output ON/OFF 1: Display off 0: Display on RESET 1: Being reset 0: Normal
Write display data	1	1	0	Write data								Writes data from data bus into display RAM.
Read display data	1	0	1	Read data								Reads data from display RAM into data bus.
Select ADC	0	1	0	1	0	1	0	0	0	0	0/1	0: CW output, 1: CCW output
Static drive ON/OFF	0	1	0	1	0	1	0	0	1	0	0/1	Selects static driving operation. 1: Static drive, 0: Normal driving
Select duty	0	1	0	1	0	1	0	1	0	0	0/1	Selects LCD duty cycle 1: 1/32, 0: 1/16
Read-Modify-Write	0	1	0	1	1	1	0	0	0	0	0	Read-modify-write ON
End	0	1	0	1	1	1	0	1	1	1	0	Read-modify-write OFF
Reset	0	1	0	1	1	1	0	0	0	1	0	Software reset

Table 1

Table 1 is the command table. The SED 1520 series identifies a data bus using a combination of A0 and R/W (RD or WR) signals. As the MPU translates a command in the internal timing only (independent from the external clock), its speed is very high. The busy check is usually not

required.

Display ON/OFF

A ₀	/RD	R/W /WR	D ₇	D ₆	D ₅	D ₄	D ₃	D ₂	D ₁	D ₀
0	1	0	1	0	1	0	1	1	1	AFH, AFH D

This command turns the

display on and off.

D=1: Display ON

D=0: Display OFF

Display Start Line

This command specifies the line address shown in Figure 1 and indicates the display line that corresponds to COM0. The display area begins at the specified line address and continues in the line address increment direction. This area having the number of lines of the specified display duty is displayed. If the line address is changed dynamically by this command, the vertical smooth scrolling and paging can be used.

A ₀	/RD	R/W /WR	D ₇	D ₆	D ₅	D ₄	D ₃	D ₂	D ₁	D ₀
COH to DFH 0	1	0	1	1	0	A ₄	A ₃	A ₂	A ₁	A ₀

This command loads display start line register.

A ₄	A ₃	A ₂	A ₁	A ₀	Line Address
0	0	0	0	0	0
0	0	0	0	1	1
		:			:
		:			:
1	1	1	1	1	31

See Figure 1.

Set Page Address

This command specifies the page address that corresponds to the low address of the display data RAM when it is accessed by the MPU. Any bit of the display data RAM can be accessed when its page address and column address are specified. The display status is not changed even when the page address is changed.

A ₀	/RD	R/W /WR	D ₇	D ₆	D ₅	D ₄	D ₃	D ₂	D ₁	D ₀
0	1	0	1	0	1	1	1	0	A ₁	A ₀

B8H to BBH

This

command loads the page address register.

A ₁	A ₀	Page
0	0	0
0	1	1
1	0	2
1	1	3

See Figure 1

Set Column Address

This command specifies a column address of the display data RAM. When the display data RAM is accessed by the MPU continuously, the column address is incremented by 1 each time it is accessed from the set address. Therefore, the MPU can access to data continuously. The column address stops to be incremented at address 80, and the page address is not changed continuously.

00H to 4FH

A ₀	/RD	R/W /WR	D ₇	D ₆	D ₅	D ₄	D ₃	D ₂	D ₁	D ₀
0	1	0	0	A ₆	A ₅	A ₄	A ₃	A ₂	A ₁	A ₀

This command loads the column address register.

A ₆	A ₅	A ₄	A ₃	A ₂	A ₁	A ₀	Column Address
0	0	0	0	0	0	0	0
0	0	0	0	0	0	1	1
			:				:
			:				:
1	0	0	1	1	1	1	79

Read Status

A ₀	/RD	R/W /WR	D ₇	D ₆	D ₅	D ₄	D ₃	D ₂	D ₁	D ₀
----------------	-----	------------	----------------	----------------	----------------	----------------	----------------	----------------	----------------	----------------

0	0	1	BUSY	ADC	ON/OFF	RESET	0	0	0	0
---	---	---	------	-----	--------	-------	---	---	---	---

Reading the command I/O register (A0=0) yields system status information.

·The busy bit indicates whether the driver will accept a command or not.

Busy=1: The driver is currently executing a command or is resetting. No new command will be accepted.

Busy=0: The driver will accept a new command.

·The ADC bit indicates the way column addresses are assigned to segment drivers.

ADC=1: Normal. Column address n→segment driver n.

ADC=0: Inverted. Column address 79-u→segment driver u.

·The ON/OFF bit indicates the current status of the display.

It is the inverse of the polarity of the display ON/OFF command.

ON/OFF=1: Display OFF

ON/OFF=0: Display ON

·The RESET bit indicates whether the driver is executing a hardware or software reset or if it is in normal operating mode.

RESET=1: Currently executing reset command.

RESET=0: Normal operation

Write Display Data

A ₀	/RD	R/W /WR	D ₇	D ₆	D ₅	D ₄	D ₃	D ₂	D ₁	D ₀
1	1	0	Write data							

Writes 8-bits of data into the display data RAM, at a location specified by the contents of the column address and page address registers and then increments the column address register by one.

Read Display Data

A ₀	/RD	R/W /WR	D ₇	D ₆	D ₅	D ₄	D ₃	D ₂	D ₁	D ₀
1	0	1	Read data							

Read 8-bits of data from the data I/O latch, updates the contents of the I/O latch with display data from the display data RAM location specified by the contents of the column address and page address registers and then increments the column address register.

After loading a new address into the column address register one dummy read is required before

valid data is obtained.

Select ADC

A0	/RD	R/W /WR	D7	D6	D5	D4	D3	D2	D1	D0
0	1	0	1	0	1	0	0	0	0	D

This command selects the

relationship between display data RAM column addresses and segment drivers.

D=1: SEGO←column address 4FH,.....(inverted)

D=0: SEGO←column address 00H,.....(normal)

This command is provided to reduce restrictions on the placement of driver ICs and routing of traces during printed circuit board design. See Figure 1 for a table of segments and column addresses for the two values of D.

Static Drive ON/OFF

A0	/RD	R/W /WR	D7	D6	D5	D4	D3	D2	D1	D0
0	1	0	1	0	1	0	0	1	0	D

Forces display on and all common

outputs to be selected.

D=1: Static drive on

D=0: Static drive off

Select Duty

A0	/RD	R/W /WR	D7	D6	D5	D4	D3	D2	D1	D0
0	1	0	1	0	1	0	1	0	0	D

This command sets the duty cycle of the LCD drive, Please set D=1, LCD duty cycle is 1/32 duty.

Read-Modify-Write

A0	/RD	R/W /WR	D7	D6	D5	D4	D3	D2	D1	D0
0	1	0	1	1	1	0	0	0	0	0

This command defeats column address register auto-increment after data reads. The current contents of the column address register are saved. This mode remains active until an End command is received.

·Operation sequence during cursor display

When the End command is entered, the column address is returned to the one used during input of Read-Modify-Write command. This function can reduce the load of MPU when data change is repeated at a specific display area (such as cursor blinking).

* Any command other than Data Read or Write can be used in the Read-Modify-Write mode. However, the Column Address Set command cannot be used.

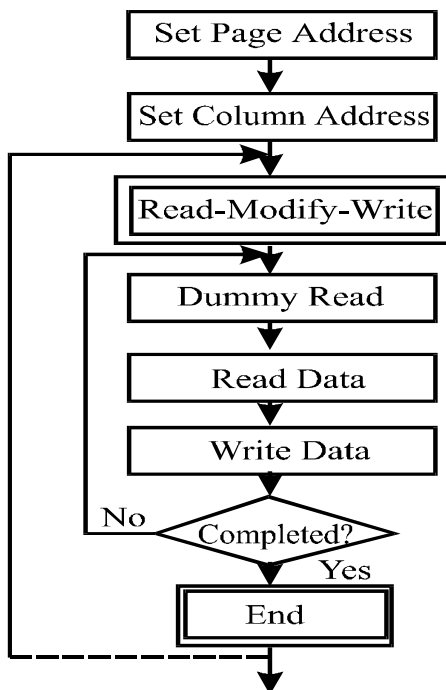

End

	A ₀	/RD	R/W /WR	D ₇	D ₆	D ₅	D ₄	D ₃	D ₂	D ₁	D ₀
EEH	0	1	0	1	1	1	0	1	1	1	0

This command cancels read-modify-write mode and restores the contents of the column address register to their value prior to the receipt of the Read-Modify-Write command.

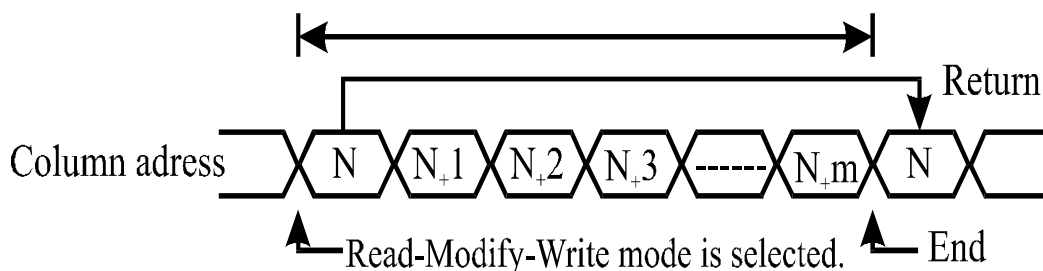

Reset

	A ₀	/RD	R/W /WR	D ₇	D ₆	D ₅	D ₄	D ₃	D ₂	D ₁	D ₀
E2H	0	1	0	1	1	1	0	0	0	1	0

This command clears

- the display start line register.
- And set page address register to 3 page.

It does not affect the contents of the display data RAM.

When the power supply is turned on, a Reset signal is entered in the RES pin. The Reset command cannot be used instead of this Reset signal.

11. Timing Characteristics

MPU Bus Read/Write (68-family MPU)

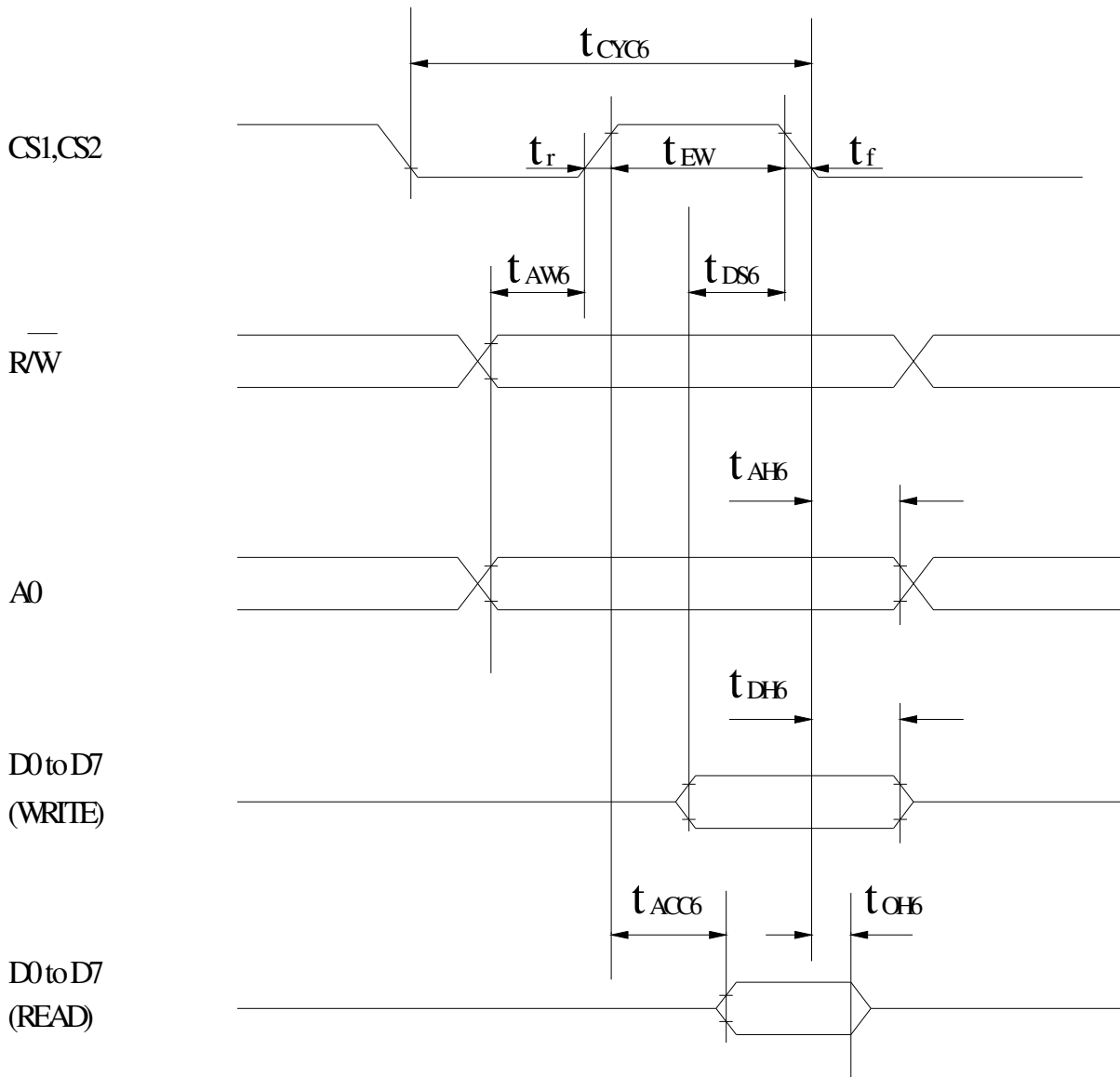

Ta=-20 to 75 deg. C, V_{dd}=5V±10 unless stated otherwise

Parameter	Symbol	Condition	Rating		Unit	Signal
			Min.	Max.		

System cycle time		t_{CYC6}	-	1000	-	ns	A0,R/W
Address setup time		t_{AW6}	-	20	-	ns	
Address hold time		t_{AH6}	-	10	-	ns	
Data setup time		t_{DS6}	-	80	-	ns	D0 to D7
Data hold time		t_{DH6}	-	10	-	ns	
Output disable time		t_{OH6}	CL=100pF	10	60	ns	
Access time		t_{ACC6}		-	90	ns	
Enable pulse width	Read	t_{EW}	-	100	-	ns	CS
	Write		-	80	-	ns	
Rise and fall time		t_r, t_f	-	-	15	ns	-

($V_{dd}=-2.7$ to -4.5 V, $T_a=-20$ to $+75^{\circ}\text{C}$)

Parameter	Symbol	Condition	Rating		Unit	Signal
			Min.	Max.		
System cycle time	t_{CYC6}	-	2000	-	ns	A0,R/W
Address setup time	t_{AW6}	-	40	-	ns	
Address hold time	t_{AH6}	-	20	-	ns	
Data setup time	t_{DS6}	-	160	-	ns	D0 to D7
Data hold time	t_{DH6}	-	20	-	ns	
Output disable time	t_{OH6}	CL=100pF	20	120	ns	
Access time	t_{ACC6}		-	180	ns	

Enable pulse width	Read	t_{EW}	-	200	-	ns	CS
	Write		-	160	-	ns	
Rise and fall time		tr, tf	-	-	15	ns	-

MPU Bus Read/Write (80-family MPU)

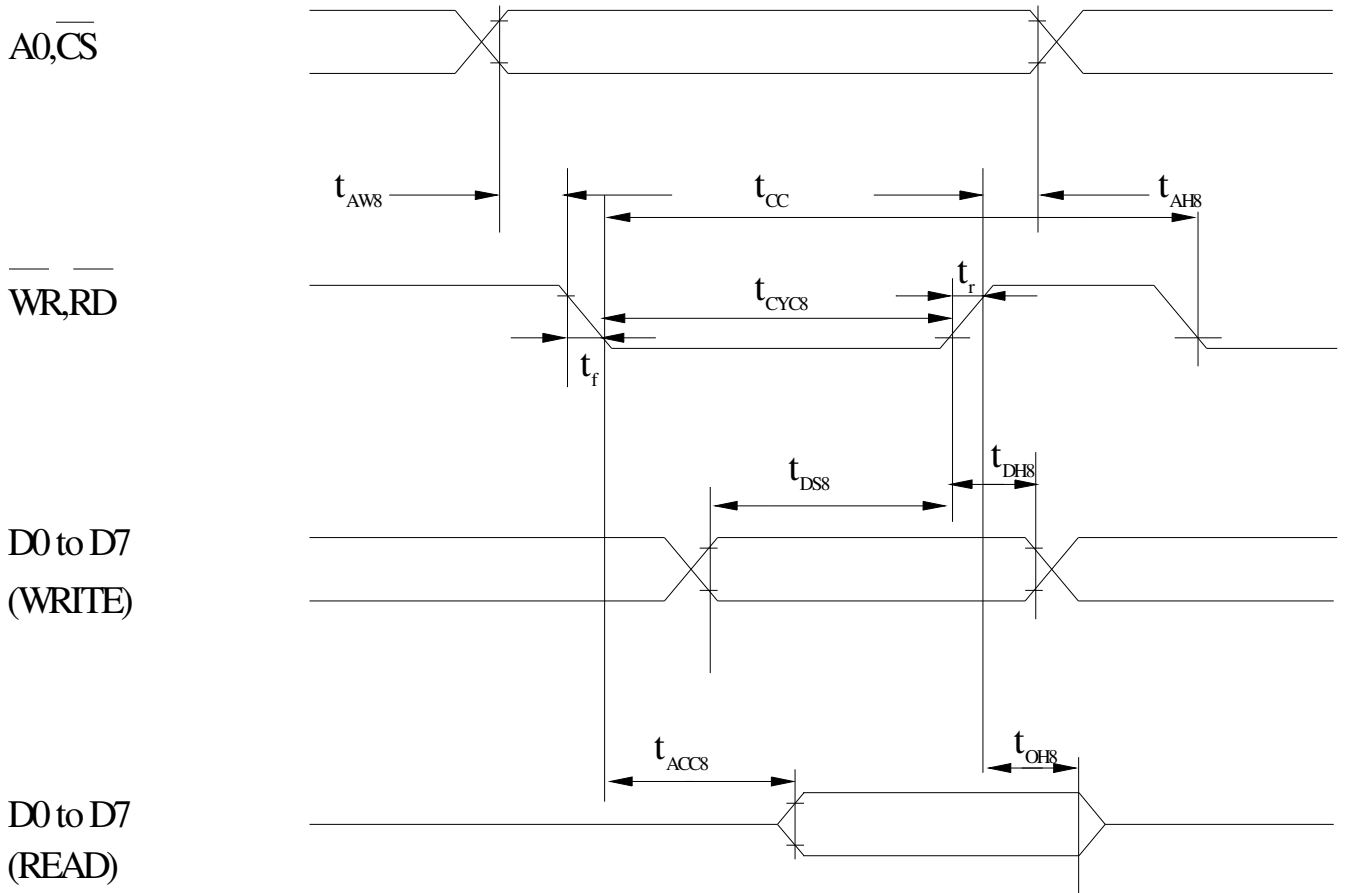

$T_a = -20 \text{ to } 75 \text{ deg. C}$, $V_{dd} = 5V \pm 10\%$ unless stated otherwise

Parameter	Symbol	Condition	Rating	Unit	Signal
-----------	--------	-----------	--------	------	--------

			Min.	Max.		
Address hold time	t_{AH8}	-	10	-	ns	A0,CS
Address setup time	t_{AW8}	-	20	-	ns	
System cycle time	t_{CYC8}	-	1000	-	ns	WR,RD
Control pulsewidth	t_{CC}	-	200	-	ns	
Data setup time	t_{DS8}	-	80	-	ns	D0 to D7
Data hold time	t_{DH8}		10	60	ns	
RD access time	t_{ACC8}	$C_L = 100 \text{ pF}$	-	90	ns	
Output disable time	t_{CH8}		10	60	ns	
Rise and fall time	t_r, t_f	-	-	15	ns	-

($V_{dd} = -2.7$ to -4.5 V, $T_a = -20$ to $+75^\circ\text{C}$)

Parameter	Symbol	Condition	Rating		Unit	Signal
			Min.	Max.		
Address hold time	t_{AH8}	-	20	-	ns	A0,CS
Address setup time	t_{AW8}	-	40	-	ns	
System cycle time	t_{CYC8}	-	2000	-	ns	WR,RD
Control pulsewidth	t_{CC}	-	400	-	ns	
Data setup time	t_{DS8}	-	160	-	ns	D0 to D7
Data hold time	t_{DH8}		20	-	ns	
RD access time	t_{ACC8}	$C_L = 100 \text{ pF}$	-	180	ns	

Output disable time	t_{CH8}		20	120	ns	
Rise and fall time	t_r, t_f	-	-	15	ns	-

12. Reliability

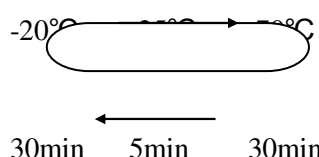
Environmental Test			
Test Item	Content of Test	Test Condition	Note
High Temperature storage	Endurance test applying the high storage temperature for a long time.	80°C 200hrs	2
Low Temperature storage	Endurance test applying the high storage temperature for a long time.	-30°C 200hrs	1,2
High Temperature Operation	Endurance test applying the electric stress (Voltage & Current) and the thermal stress to the element for a long time.	70°C 200hrs	—
Low Temperature Operation	Endurance test applying the electric stress under low temperature for a long time.	-20°C 200hrs	1
High Temperature/ Humidity Operation	The module should be allowed to stand at 60°C,90%RH max For 96hrs under no-load condition excluding the polarizer, Then taking it out and drying it at normal temperature.	60°C,90%RH 96hrs	1,2
Thermal shock resistance	The sample should be allowed stand the following 10 cycles of operation 	-20°C/70°C 10 cycles	—
Vibration test	Endurance test applying the vibration during transportation and using.	Total fixed amplitude : 1.5mm Vibration Frequency : 10~55Hz One cycle 60 seconds to 3 directions of X,Y,Z for Each 15 minutes	3
Static electricity test	Endurance test applying the electric stress to the terminal.	VS=800V,RS=1.5kΩ CS=100pF 1 time	—

Content of Reliability Test (wide temperature, -20°C~70°C)

Note1: No dew condensation to be observed.

Note2: The function test shall be conducted after 4 hours storage at the normal Temperature and humidity after remove from the test chamber.

Note3: Vibration test will be conducted to the product itself without putting it in a container.

14.Backlight Information

PARAMETER	SYMBOL	MIN	TYP	MAX	UNIT	TEST CONDITION
Supply Current	I _{LED}	16	20	30	mA	V=3.5V
Supply Voltage	V	3.4	3.5	3.6	V	-
Reverse Voltage	V _R	-	-	5	V	-
Luminous Intensity	I _V	10	-	-	CD/M ²	I _{LED} =20mA
Wave Length	λ _p	-	-	-	nm	I _{LED} =20mA
Life Time	-	-	50000	-	Hr.	I _{LED} =20mA
Color	White					



N
ote:
The

LED of B/L is drive by current only, drive voltage is for reference only.

drive voltage can make driving current under safety area (current between minimum and maximum).

15. Inspection specification

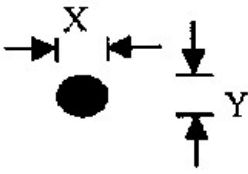
NO	Item	Criterion	AQL
01	Electrical Testing	1.1 Missing vertical, horizontal segment, segment contrast defect. 1.2 Missing character , dot or icon. 1.3 Display malfunction. 1.4 No function or no display. 1.5 Current consumption exceeds product specifications. 1.6 LCD viewing angle defect. 1.7 Mixed product types. 1.8 Contrast defect.	0.65
02	Black or white spots on LCD (display only)	2.1 White and black spots on display $\leq 0.25\text{mm}$, no more than three white or black spots present. 2.2 Densely spaced: No more than two spots or lines within 3mm	2.5
03	LCD black spots, white spots, contamination (non-display)	3.1 Round type : As following drawing $\Phi = (x + y) / 2$	2.5

			SIZE	Acceptable Q TY	
			$\Phi \leq 0.10$	Accept no dense	
			$0.10 < \Phi \leq 0.20$	2	
			$0.20 < \Phi \leq 0.25$	1	
			$0.25 < \Phi$	0	
		3.2 Line type : (As following drawing)			2.5
	Length	Width	Acceptable Q TY		
	---	$W \leq 0.02$	Accept no dense		
	$L \leq 3.0$	$0.02 < W \leq 0.03$	2		
	$L \leq 2.5$	$0.03 < W \leq 0.05$			
	---	$0.05 < W$	As round type		
04	Polarizer bubbles	If bubbles are visible, judge using black spot specifications, not easy to find, must check in specify direction.	Size Φ	Acceptable Q TY	2.5
			$\Phi \leq 0.20$	Accept no dense	
			$0.20 < \Phi \leq 0.50$	3	
			$0.50 < \Phi \leq 1.00$	2	
			$1.00 < \Phi$	0	
			Total Q TY	3	

NO	Item	Criterion	AQL
----	------	-----------	-----

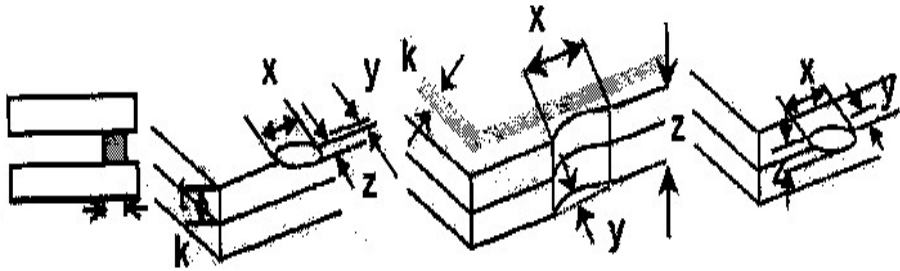
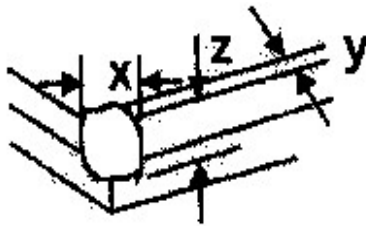
05	Scratches	Follow NO.3 LCD black spots, white spots, contamination																
06	Chipped glass	<p>Symbols Define: x: Chip length y: Chip width z: Chip thickness k: Seal width t: Glass thickness a: LCD side length L: Electrode pad length:</p> <p>6.1 General glass chip : 6.1.1 Chip on panel surface and crack between panels:</p>  <table border="1" data-bbox="443 840 1348 1227"> <tr> <td>z: Chip thickness</td> <td>y: Chip width</td> <td>x: Chip length</td> </tr> <tr> <td>$Z \leq 1/2t$</td> <td>Not over viewing area</td> <td>$x \leq 1/8a$</td> </tr> <tr> <td>$1/2t < z \leq 2t$</td> <td>Not exceed 1/3k</td> <td>$x \leq 1/8a$</td> </tr> </table> <p>⊙If there are 2 or more chips, x is total length of each chip.</p> <p>6.1.2 Corner crack:</p>  <table border="1" data-bbox="443 1848 1348 2042"> <tr> <td>z: Chip thickness</td> <td>y: Chip width</td> <td>x: Chip length</td> </tr> <tr> <td>$Z \leq 1/2t$</td> <td>Not over viewing</td> <td>$x \leq 1/8a$</td> </tr> </table>	z: Chip thickness	y: Chip width	x: Chip length	$Z \leq 1/2t$	Not over viewing area	$x \leq 1/8a$	$1/2t < z \leq 2t$	Not exceed 1/3k	$x \leq 1/8a$	z: Chip thickness	y: Chip width	x: Chip length	$Z \leq 1/2t$	Not over viewing	$x \leq 1/8a$	2.5
z: Chip thickness	y: Chip width	x: Chip length																
$Z \leq 1/2t$	Not over viewing area	$x \leq 1/8a$																
$1/2t < z \leq 2t$	Not exceed 1/3k	$x \leq 1/8a$																
z: Chip thickness	y: Chip width	x: Chip length																
$Z \leq 1/2t$	Not over viewing	$x \leq 1/8a$																

			area	
		$1/2t < z \leq 2t$	Not exceed $1/3k$	$x \leq 1/8a$
<p>⊙If there are 2 or more chips, x is the total length of each chip.</p>				

NO	Item	Criterion	AQL
06	Glass	Symbols :	2.5

crack

x: Chip length y: Chip width z: Chip thickness
 k: Seal width t: Glass thickness a: LCD side length
 L: Electrode pad length

6.2 Protrusion over terminal :

6.2.1 Chip on electrode pad :

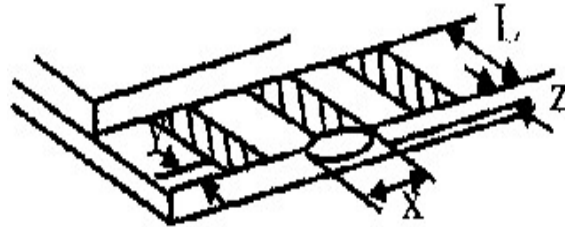

y: Chip width	x: Chip length	z: Chip thickness
$y \leq 0.5\text{mm}$	$x \leq 1/8a$	$0 < z \leq t$

6.2.2 Non-conductive portion:

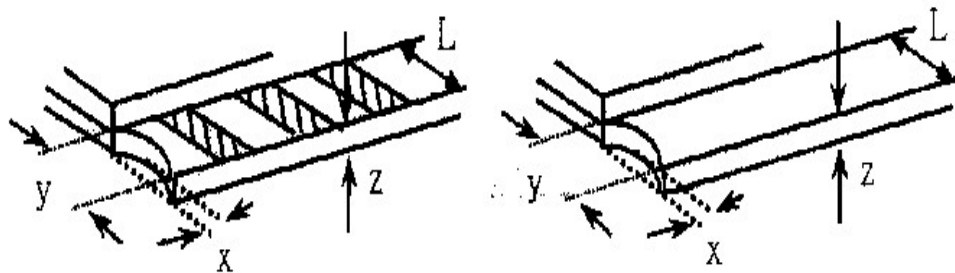

y: Chip width	x: Chip length	z: Chip thickness
$y \leq L$	$x \leq 1/8a$	$0 < z \leq t$

⊙If the chipped area touches the ITO terminal, over 2/3 of the ITO must remain and be inspected according to electrode terminal specifications.

⊙If the product will be heat sealed by the customer, the alignment mark not be damaged.

6.2.3 Substrate protuberance and internal crack.

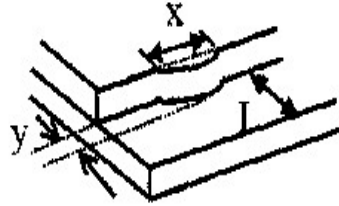

y: width	x: length
$y \leq 1/3L$	$x \leq a$

NO	Item	Criterion	AQL
07	Cracked glass	The LCD with extensive crack is not acceptable.	2.5
08	Backlight elements	<p>8.1 Illumination source flickers when lit.</p> <p>8.2 Spots or scratched that appear when lit must be judged. Using LCD spot, lines and contamination standards.</p> <p>8.3 Backlight doesn't light or color wrong.</p>	<p>0.65</p> <p>2.5</p> <p>0.65</p>
09	Bezel	<p>9.1 Bezel may not have rust, be deformed or have fingerprints, stains or other contamination.</p> <p>9.2 Bezel must comply with job specifications.</p>	<p>2.5</p> <p>0.65</p>

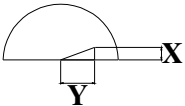
10	PCB、COB	<p>10.1 COB seal may not have pinholes larger than 0.2mm or contamination.</p> <p>10.2 COB seal surface may not have pinholes through to the IC.</p> <p>10.3 The height of the COB should not exceed the height indicated in the assembly diagram.</p> <p>10.4 There may not be more than 2mm of sealant outside the seal area on the PCB. And there should be no more than three places.</p> <p>10.5 No oxidation or contamination PCB terminals.</p> <p>10.6 Parts on PCB must be the same as on the production characteristic chart. There should be no wrong parts, missing parts or excess parts.</p> <p>10.7 The jumper on the PCB should conform to the product characteristic chart.</p> <p>10.8 If solder gets on bezel tab pads, LED pad, zebra pad or screw hold pad, make sure it is smoothed down.</p> <p>10.9 The Scraping testing standard for Copper Coating of PCB</p>  <p style="text-align: center;">$X * Y \leq 2\text{mm}^2$</p>	<p>2.5</p> <p>2.5</p> <p>0.65</p> <p>2.5</p> <p>2.5</p> <p>0.65</p> <p>0.65</p> <p>2.5</p> <p>2.5</p>
11	Soldering	<p>11.1 No un-melted solder paste may be present on the PCB.</p> <p>11.2 No cold solder joints, missing solder connections, oxidation or icicle.</p> <p>11.3 No residue or solder balls on PCB.</p> <p>11.4 No short circuits in components on PCB.</p>	<p>2.5</p> <p>2.5</p> <p>2.5</p> <p>0.65</p>

--	--	--	--

NO	Item	Criterion	AQL
12	General appearance		2.5
		12.1 No oxidation, contamination, curves or, bends on interface Pin (OLB) of TCP.	0.65
		12.2 No cracks on interface pin (OLB) of TCP.	2.5
		12.3 No contamination, solder residue or solder balls on product.	2.5
		12.4 The IC on the TCP may not be damaged, circuits.	2.5
		12.5 The uppermost edge of the protective strip on the interface pin must be present or look as if it cause the interface pin to sever.	2.5
		12.6 The residual rosin or tin oil of soldering (component or chip component) is not burned into brown or black color.	0.65
		12.7 Sealant on top of the ITO circuit has not hardened.	0.65
		12.8 Pin type must match type in specification sheet.	0.65
		12.9 LCD pin loose or missing pins.	0.65
		12.10 Product packaging must the same as specified on packaging specification sheet.	
12.11 Product dimension and structure must conform to			

		product specification sheet.	
--	--	------------------------------	--

16. Material List of Components for RoHs

1. WINSTAR Display Co., Ltd hereby declares that all of or part of products (with the mark “#”in code), including, but not limited to, the LCM, accessories or packages, manufactured and/or delivered to your company (including your subsidiaries and affiliated company) directly or indirectly by our company (including our subsidiaries or affiliated companies) do not intentionally contain any of the substances listed in all applicable EU directives and regulations, including the following substances.

Exhibit A : The Harmful Material List

Material	(Cd)	(Pb)	(Hg)	(Cr6+)	PBBs	PBDEs
Limited Value	100 ppm	1000 ppm	1000 ppm	1000 ppm	1000 ppm	1000 ppm
Above limited value is set up according to RoHS.						

2.Process for RoHS requirement :

(1) Use the Sn/Ag/Cu soldering surface ; the surface of Pb-free solder is rougher than we used before.

(2) Heat-resistance temp. :

Reflow : 250℃,30 seconds Max. ;

Connector soldering wave or hand soldering : 320℃, 10 seconds max.

(3) Temp. curve of reflow, max. Temp. : 235±5℃ ;

Recommended customer's soldering temp. of connector : 280℃, 3 seconds.



winstar

LCM Sample Estimate Feedback Sheet

Module Number : _____

Page: 1

1 Panel Specification :

1. Panel Type : Pass NG

2. View Direction : Pass NG
3. Numbers of Dots : Pass NG
4. View Area : Pass NG
5. Active Area : Pass NG
6. Operating Temperature : Pass NG
7. Storage Temperature : Pass NG
8. Others : Pass NG

2 Mechanical Specification :

1. PCR Size : Pass NG
2. Frame Size : Pass NG
3. Material of Frame : Pass NG
4. Connector Position : Pass NG
5. Fix Hole Position : Pass NG
6. Backlight Position : Pass NG
7. Thickness of PCR : Pass NG
8. Height of Frame to PCR : Pass NG
9. Height of Module : Pass NG
10. Others : Pass NG

3 Relative Hole Size :

1. Pitch of Connector : Pass NG
2. Hole size of Connector : Pass NG
3. Mounting Hole size : Pass NG
4. Mounting Hole Type : Pass NG
5. Others : Pass NG

4 Backlight Specification :

1. R/I Type : Pass NG
2. R/I Color : Pass NG
3. R/I Driving Voltage (Reference for LED Type) : Pass NG
4. R/I Driving Current : Pass NG
5. Brightness of R/I : Pass NG
6. R/I Solder Method : Pass NG
7. Others : Pass NG

>> Go to page 2 <<



Module Number : _____

Page: 2

5 Electronic Characteristics of Module :

- | | | |
|------------------------------|-------------------------------|-----------------------------|
| 1. Input Voltage : | <input type="checkbox"/> Pass | <input type="checkbox"/> NG |
| 2. Supply Current : | <input type="checkbox"/> Pass | <input type="checkbox"/> NG |
| 3. Driving Voltage for LCD : | <input type="checkbox"/> Pass | <input type="checkbox"/> NG |
| 4. Contrast for LCD : | <input type="checkbox"/> Pass | <input type="checkbox"/> NG |
| 5. R/I Driving Method : | <input type="checkbox"/> Pass | <input type="checkbox"/> NG |
| 6. Negative Voltage Output : | <input type="checkbox"/> Pass | <input type="checkbox"/> NG |
| 7. Interface Function : | <input type="checkbox"/> Pass | <input type="checkbox"/> NG |
| 8. LCD Uniformity : | <input type="checkbox"/> Pass | <input type="checkbox"/> NG |
| 9. ESD test : | <input type="checkbox"/> Pass | <input type="checkbox"/> NG |
| 10. Others : | <input type="checkbox"/> Pass | <input type="checkbox"/> NG |

6 Summary :

Sales signature : _____

Customer Signature : _____

Date : / /