

REV.	DESCRIPTION	DRAWN	CHECKED	APPROVED
A	NEW RELEASE	LJC 06/18/05'	~	LJC 06/18/05'
B	DRAWING UPDATE	JLZ 03/06/18'	~	

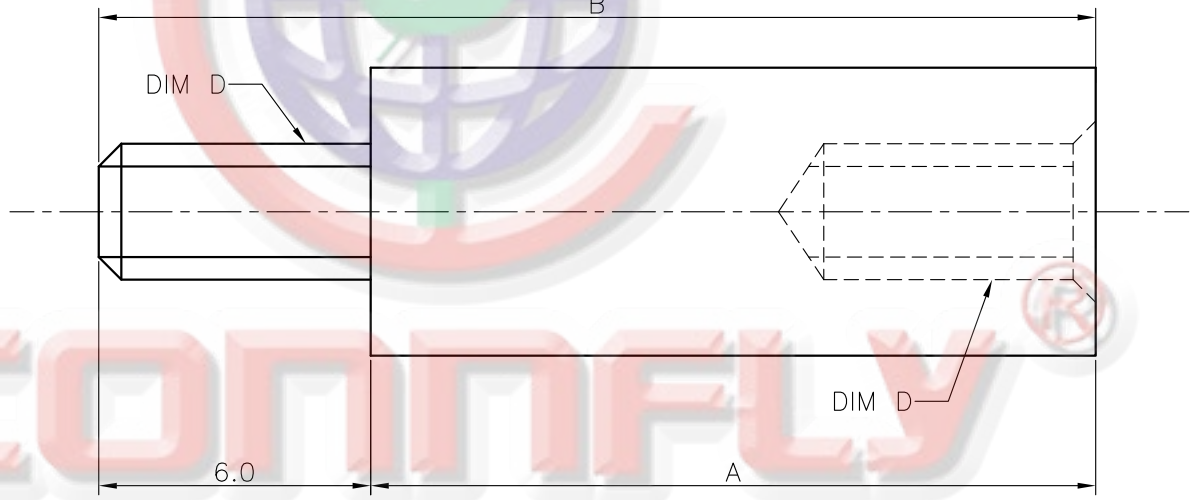
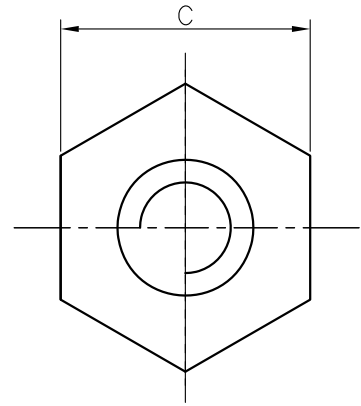

NOTES:

- 1.Materials: Copper alloy.
- 2.Plating: Nickel plating.
- 3.Part number code:

H - LXXXX - XXXX -5 -XX - 1N1W

Thread type: DIM D
 03: M3.0
 04: M4.0*0.7

DIM C:
 5: 5.5mm

DIM B:
 1200: 12.0mm

 4600: 46.0mm

DIM A:
 0600: 6.0mm

 4000: 40.0mm

Tel: 86-574-63508787
 Fax: 86-574-63510817
 E-mail: sale@connfly.com
 http://www.connfly.com
 Add: East Industry Zone, KuangYan
 Town, Ningbo, China
 P.C: 315336

GENERAL TOLERANCE		ANGLE TOLERANCE	
X.	±0.60	X.	±5°
.X	±0.38	.X	±3°
.XX	±0.25	.XX	±2°
DRAWING TYPE		CUSTOMER DRAWING	
SCALE		1:1	SHEET 1 OF 1
DRAWING NO.		H-LXXXX-XXXX-5-XX-1N1W	

PROJECTION		TITLE	Screws	
UNITS	mm	SERIES	Hardwares SERIES	
SHEET SIZE	A4			

晨翔电子有限公司
CONNFLY CONNFLY ELECTRONIC CO. LTD