

REV - DESCRIPT - DATE - APPRVD
 C UPDATED JUNE 1,07 AG
 D NAME CORRECTED JUNE 8,07 AG
 E SHELL DIM'S ADDED OCT4,07 A.G.

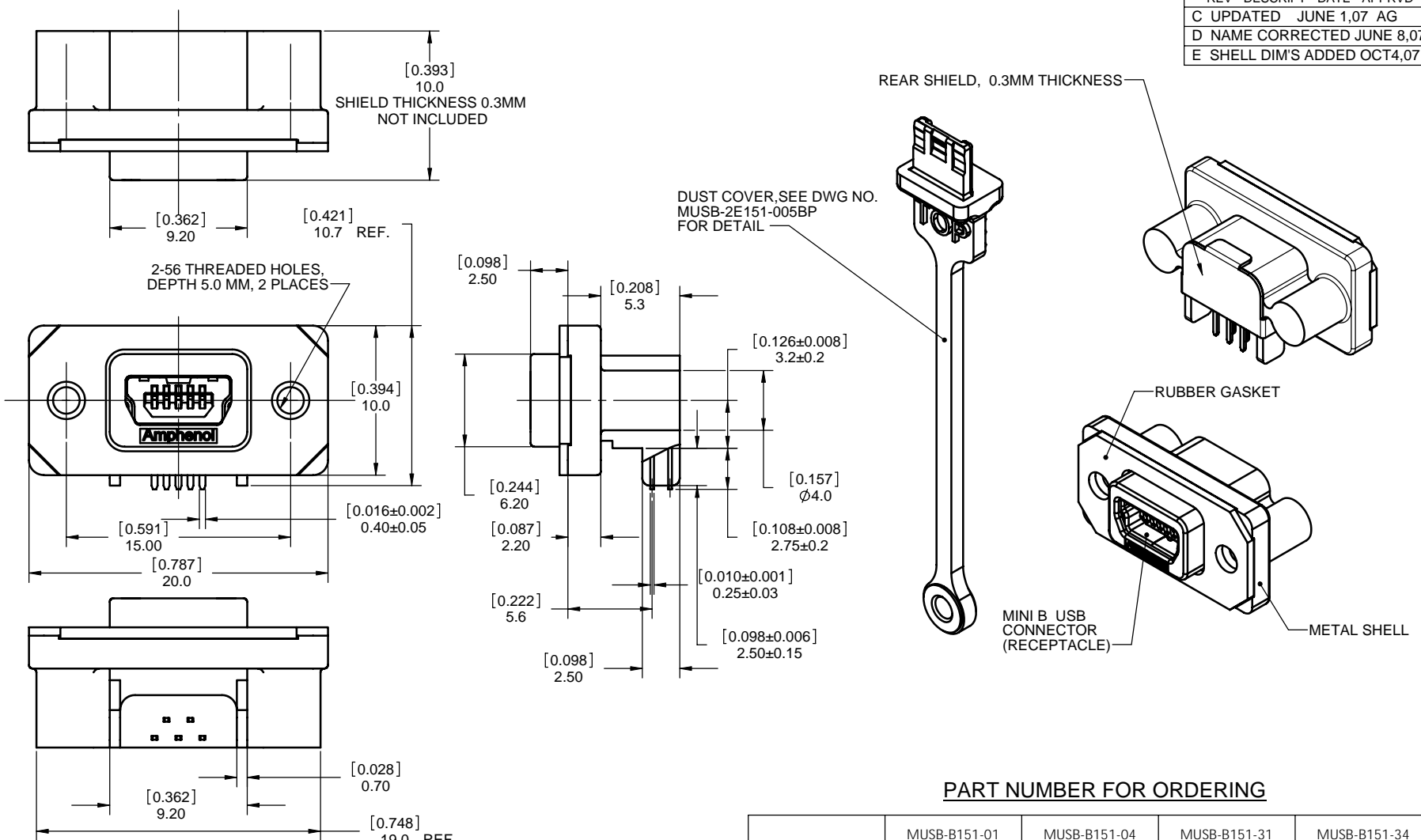

PART NUMBER FOR ORDERING

	MUSB-B151-01	MUSB-B151-04	MUSB-B151-31	MUSB-B151-34
REAR SHIELD	NO	NO	YES	YES
DUST COVER	YES	NO	YES	NO

NOTES:

- MATERIAL:**
 - SHELL: ZINC ALLOY DIE CAST, NICKEL PLATED.
 - CONTACTS: PHOSPHOR BRONZE, GOLD OVER NICKEL PLATED.
 - GASKET: SILICONE RUBBER.
 - REAR SHIELD: BRASS ALLOY, NICKEL PLATED.
 - DUST COVER: SILICONE RUBBER WITH NICKEL PLATED BRASS BUSHING.
- FEATURE:** SEALED CONNECTOR IN THE MATED AND UNMATED CONDITIONS.
- OPERATING TEMPERATURE:** -40°C TO +85°C.
- ENVIRONMENT PERFORMANCE:** IP67.
- PART IS ROHS COMPLIANT PER EU DIRECTIVE 2002/95/EC AND AMENDMENTS.**
- PART IS UL94V-0 COMPLIANT.**



UNLESS OTHERWISE SPECIFIED DIMENSIONS ARE IN MILLIMETER TOLERANCES ARE:		APPROVALS	DATE	Amphenol Canada Corp.	
DECIMALS	ANGLES	DRAWN	MAR15/07		
.XX ±.10	± 1°	S.SEMENOV		TITLE RUGGED MINI-B USB, RECEPTACLE, RIGHT ANGLE	
.X ±.25		DESIGNED	MAR15/07		
MATERIAL AND FINISH		CHECKED		SIZE	DWG. NO.
REF.		QA APP'D		C	P-MUSB-B151-XX
CODE IDENT. NO.		IE APP'D		SCALE	PROJECT
		DWG APP'D	MAR15/07	1:0.2	MUSB
		A.GREEN		SHEET	1 OF 2

DO NOT SCALE DRAWING
 THIS DOCUMENT CONTAINS PROPRIETARY INFORMATION AND SUCH INFORMATION MAY NOT BE DISCLOSED TO OTHERS FOR ANY PURPOSE OR USED FOR MANUFACTURING PURPOSES WITHOUT PERMISSION FROM AMPHENOL CANADA CORP.

REV - DESCRIPT - DATE - APPRVD
C UPDATED JUNE 1,07 AG
D NAME CORRECTED JUNE 8,07 AG
E SHELL DIM'S ADDED OCT4,07 A.G.

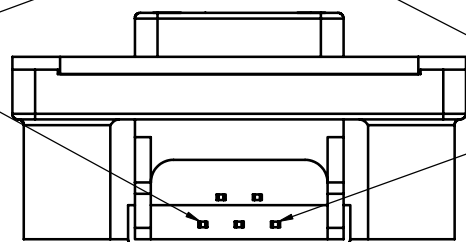
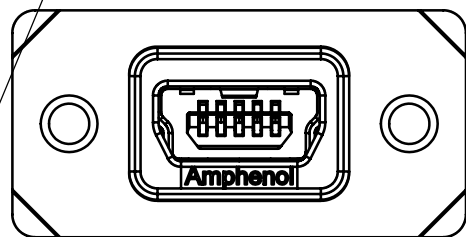
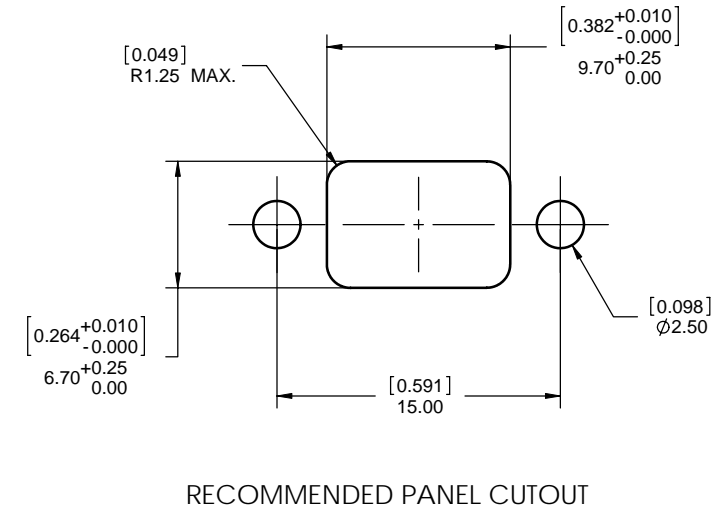
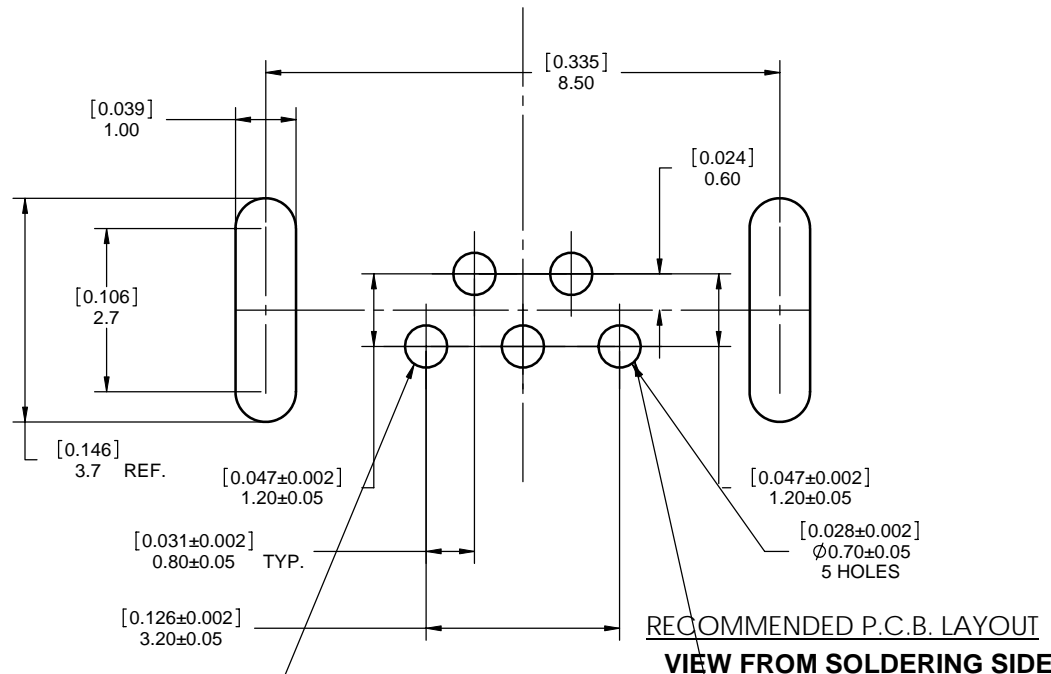

PIN #1

PIN #5



UNLESS OTHERWISE SPECIFIED DIMENSIONS ARE IN MILLIMETER TOLERANCES ARE:		APPROVALS	DATE	Amphenol Canada Corp.	
DECIMALS	ANGLES	DRAWN	MAR15/07		
.XX ±.10	± 1°	S.SEMENOV		TITLE RUGGED MINI-B USB, RECEPTACLE, RIGHT ANGLE	
.X ±.25		DESIGNED	MAR15/07		
MATERIAL AND FINISH		CHECKED		SIZE	DWG. NO.
		QA APP'D		C	P-MUSB-B151-XX
REF.		IE APP'D		SCALE	PROJECT
		DWG APP'D	MAR15/07	1:0.2	MUSB
CODE IDENT. NO.		A.GREEN		SHEET	2 OF 2

DO NOT SCALE DRAWING
THIS DOCUMENT CONTAINS PROPRIETARY INFORMATION AND SUCH INFORMATION MAY NOT BE DISCLOSED TO OTHERS FOR ANY PURPOSE OR USED FOR MANUFACTURING PURPOSES WITHOUT PERMISSION FROM AMPHENOL CANADA CORP.