

HMZ-435CHS Humidity module specifications

1. Application range :

The HMZ-435CHS module consist of an HCZ sensor and integrated circuit to provide a linear DC Voltage for 0-100%RH to enable easy user application of the HCZ sensor. They are specifically designed for use appliances and controllers.

Feature	Application
Wide humidity operation range	Air condition ,humidifier, Dehumidifier.
Linear DC Output	Humidity controller, Humidity transmitter.
Easy operation	Hygrometer, Hygro-recorder.
Long-term stability	Copying machine.
Small and economical	Clock ,Weather-forecast barometer.

2. Electrical characteristics :

2.1 Sensing element (Humidity) : HMZ-435CHS A Humidity sensor “GHITRON HCZ“

2.2 Supply Voltage(Vin) : 5VDC±5%

2.3 Current Consumption : 5mA max:(2mA avg.)

2.4 Operating Range

Temperature : 0 to 60°C

Humidity : 95%RH or less

2.5 Storage

Temperature : -20 to 65°C

Humidity : 95%RH or less

2.6 Humidity transmitting

Range : 10 to 90%RH

2.7 Accuracy :

Temperature : Resistance(1%) : 50±0.5KΩ (at 25±0.2°C)

Humidity : ±5%RH (at 25°C , 60%RH, Vin=5.00VDC)

2.8 Humidity Output 0~3.3V At 25 ,Vin=5.00VDC

Signal(Reference) : (Output Impedance approx:5KΩ)

Humidity(%RH)	10	20	30	40	50	60	70	80	90
Output Voltage(V)	0.88	1.13	1.42	1.74	2.06	2.37	2.66	2.90	3.07

PRODUCT SPECIFICATIONS

HMZ-435CHS

2.9 Temperature Output Using thermistor 503 $R(25^{\circ}\text{C})=50\text{K}\Omega\pm 1\%$,
Signal(Reference) : $B(25/85)=3950\text{K}\pm 1\%$

Temperature($^{\circ}\text{C}$)	0	10	20	25	30	40	50	60
Resistance($\text{K}\Omega$)	160.56	98.714	62.328	50.0	40.356	26.756	18.138	12.554

2.10 Humidity Output 0~3.5V characteristics :

HMZ-435CHS Humidity Output 0~3.5V characteristics

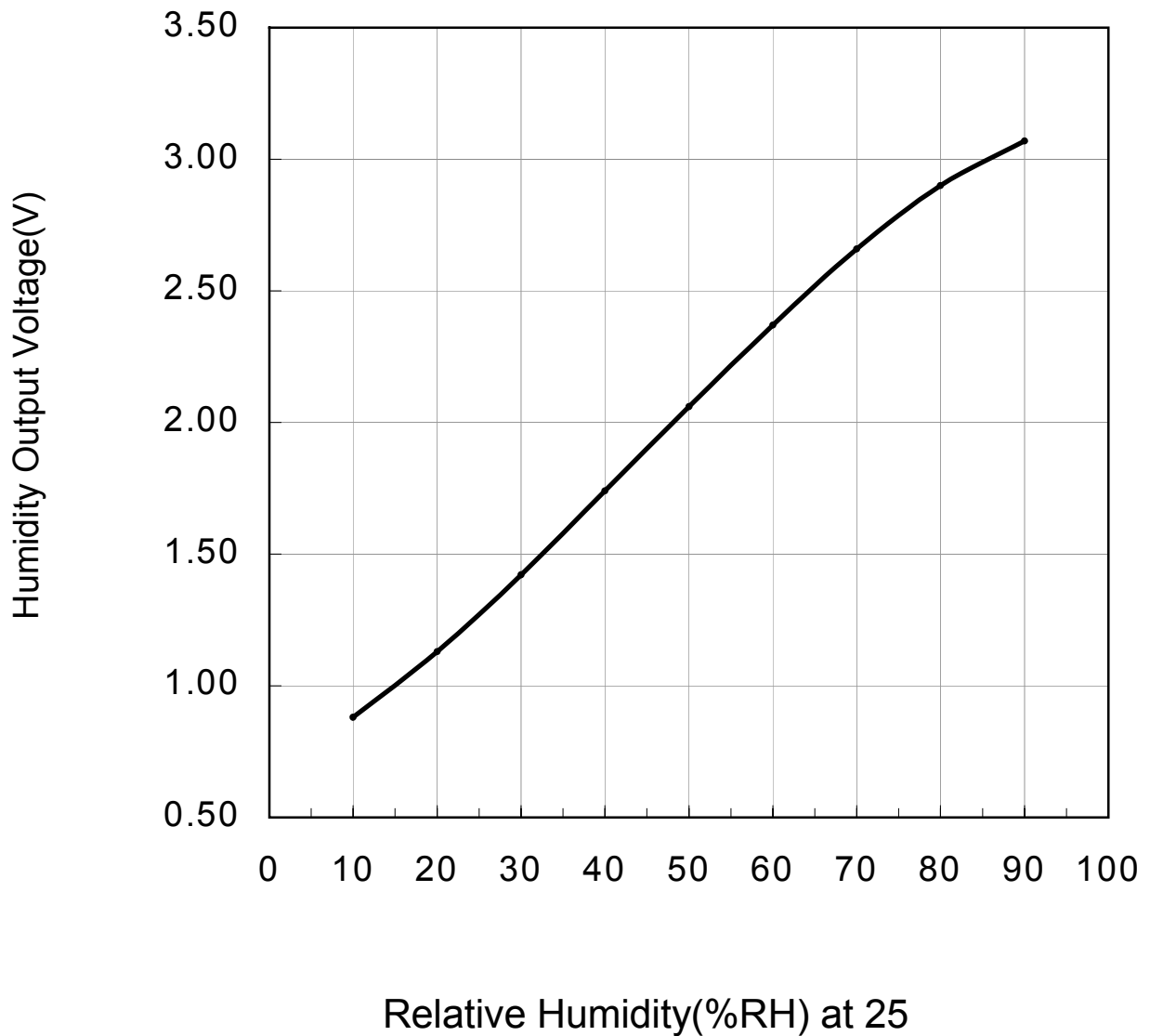

2.11 HMZ-435CHS module Humidity Output 0~3.5V v.s Temperature characteristics :

	10	15	20	25	30	35	40
--	----	----	----	----	----	----	----

PRODUCT SPECIFICATIONS

HMZ-435CHS

10%RH	095	0.94	0.94	0.88	0.83	0.80	0.79
20%RH	1.19	1.16	1.16	1.13	1.06	1.05	1.02
30%RH	1.46	1.43	1.43	1.42	1.36	1.36	1.33
40%RH	1.75	1.73	1.74	1.74	1.70	1.70	1.67
50%RH	2.06	2.05	2.06	2.06	2.05	2.05	2.20
60%RH	2.36	2.36	2.37	2.37	2.38	2.38	2.36
70%RH	2.65	2.65	2.66	2.66	2.67	2.67	2.66
80%RH	2.91	2.90	2.90	2.90	2.89	2.90	2.88
90%RH	3.12	3.08	3.08	3.07	3.01	3.04	3.00

Remark : Remark: Accuracy : $\pm 5\%RH$ (at 25 , 60%RH, $V_{in}=5.00VDC$)

Output range : 2.200~2.520 V(0~3.5V Output)

3. Configuration & Dimensions (Units :mm) :

3.1 Model No. HMZ-435CHS Drawing

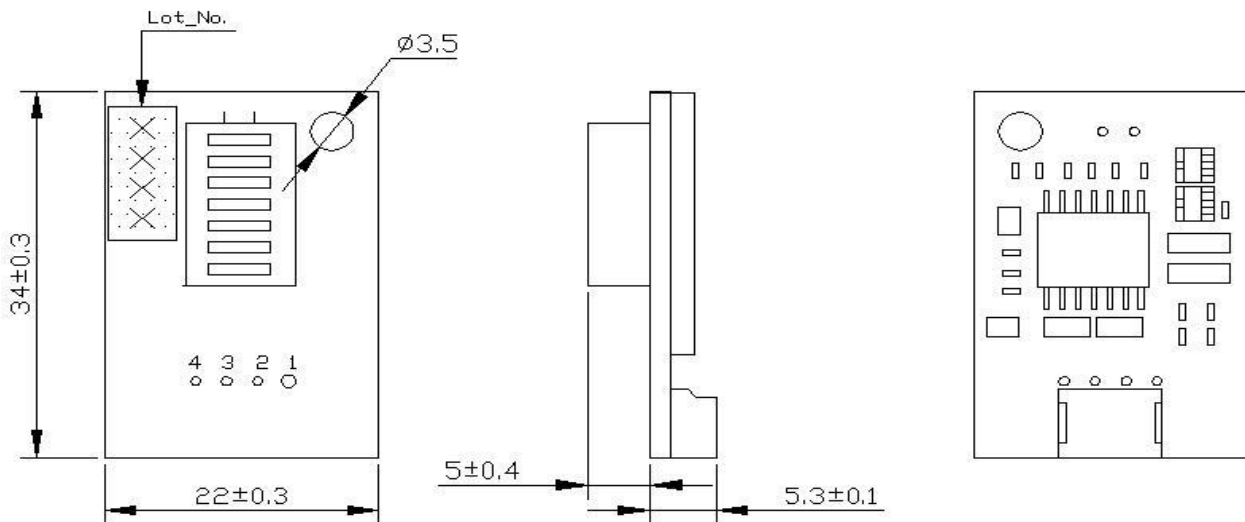

3.1 Terminal Connection :

Terminal	Content.
Pin1	Power Source 5V DC.
Pin2	Humidity Output.
Pin3	GND.
Pin4	Temp Output 50k Ω (at 25°C).

Remark : Please pay attention to the power source and GND polarity position.

4. Typical Applications :

4.1 Pin2 Humidity output (DC:V)

4.2 Pin4 Temperature(Thermistor) output (DC:V)

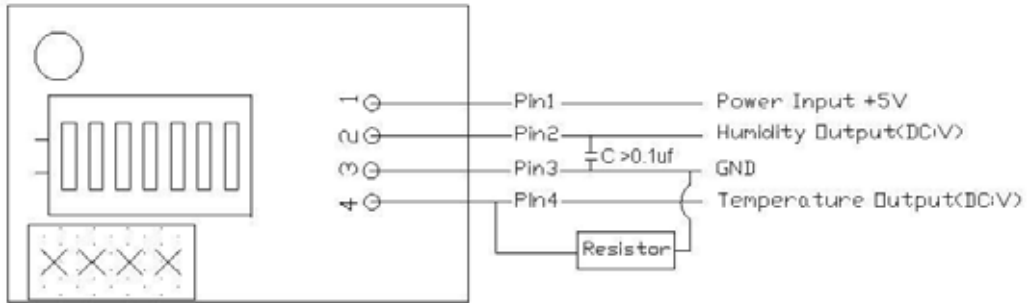

5. Order Form :

HMZ-435CHS is the module with the 0~3.5V voltage output for humidity and temperature output 50KΩ (at 25°C,.) °

HMZ-435CHS Configure of definition.	
Input Voltage	5V
Humidity Output Voltage	0~3.5V
Temperature Output	50kΩ (at 25°C)
Terminal Connector	HMZ-435CHS : S4B-ZR-SM3A(4pins · Pitch = 1.5 mm)
Accuracy	±5%RH
Sensing element (Humidity) :	Humidity sensor “ GHITRON HCZ “
Output Range :	10~90%RH

6. Reliability test :

No.	ITEM	METHOD	REQUIREMENT
6.1	Impact test	To drop Module 3time at random on to a hard wooden plate from 1meter above high.	No breakage, nor cracks. Should be electrically normal.
6.2	Vibration test	Vibration test in X-Y-Z axis for 30min. under 10-55Hz frequency, 1.5mm(10-55-10Hz)amplitude.	No breakage, nor cracks. Should be electrically normal.
6.3	Heat resistance	To leave module in an ambient of 65°C and 30%RH max. for 48hours.	Within ±5%RH
6.4	Cool resistance	To leave module in an ambient of -10°C and 30%RH max. for 48hours.	Within ±5%RH
6.5	Humidity resistance	To leave module in an ambient of 40°C and 95%RH for 48hours.	Within ±5%RH
6.6	Temperature cycle test	5 cycles. 1cycle stands for leaving module under -10°C for 1hour,and raise ambient temp. up to 65°C for next 1hour.Then,leave it	Within ±5%RH

PRODUCT SPECIFICATIONS

HMZ-435CHS

		another 1hour,and lower temp. to -10°C for next 1hour.	
--	--	--	--

Remarks :

- (1) All standard figures are based on humidity variation under 60%RH(25°C) °
- (2) Upon completion of all tests, The module will be left over under nominal environment and humidity for 24hours.

7. Packing :

There are 50 pieces of modules to be packed in one tray.

8. Caution remarks on operation :

8.1 To avoid direct application of DC voltage on humidity sensor.

8.2 To protect sensor from dewfall and drenching.

8.3 To avoid and operation of humidity sensors in the following environmental ambient.

8.3.1 Salt

8.3.2 Inorganic gas Sulfide dioxide, Chlorine, Ammonium, etc.

8.3.3 Organic gas Alcoholic, Glycols, Aldehydes, etc.

8.4 Recommendable storage condition :

Temperature range 10~40

Humidity Range 90%RH or Less.

8.5 Do not store humidity sensors long period of time in an 60 ambient, due to some occasion of degradation on sensor housing case.

Remark : We have the right to revise specification and product configurations without notice.