

- High load voltage - up to 480VAC
- 4 - 32VDC or 90 - 250VAC control voltage
- Zero cross-over or Random switching
- LED input indicator
- Finger protected terminals
- RoHS Compliant
- UL approved

Output (load)

Load type		SPST-NO (1 N/O) Resistive
Load current		10A, 20A, 25A, 30A, 40A, 60A, or 80A
Load switching voltage	AC V _{rms}	24 - 240V, 40 - 480V
Maximum peak voltage	AC V _{pk}	900V
Switch type		Zero Cross (std) or Random
On voltage drop	V AC	1.5V
Leakage current (off state)	mA	≤ 7mA

Input (control)

Control voltage	V	D: 4 - 32VDC or A: 90 - 250VAC
Control current	mA	< 20mA
Turn-on voltage	V _{min}	D: 3VDC / A: 90VAC
Turn-off voltage	V	D: 1VDC / A: 10VAC

Insulation

Insulation resistance		≤ 500MΩ at 500VDC, 50%RH
Dielectric strength	V AC	≥ 2500V

General Data

Operating time	mS	≤ 10ms
Release time	mS	≤ 10ms
Dimensions	L x W x H	60 x 45.1 x 27.5mm
Weight		98g
Ambient temperature	storage	-30 to 80°C
	operating	-30 to 80°C (with derating). A heat sink may be required.

Ordering Code

Dimensions

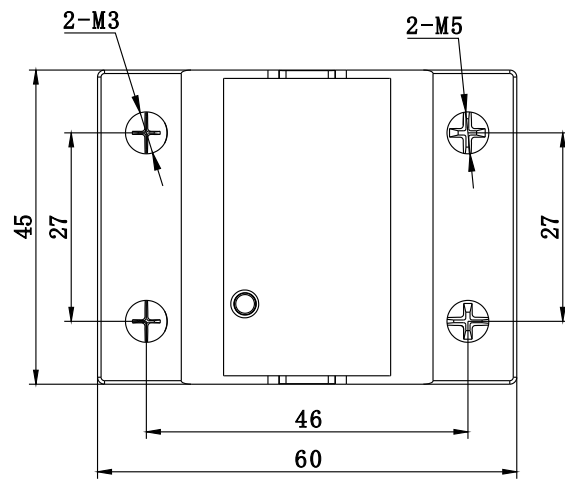
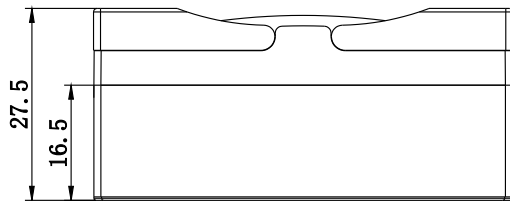

Dimensions in mm

Heat Sinks

HH-060

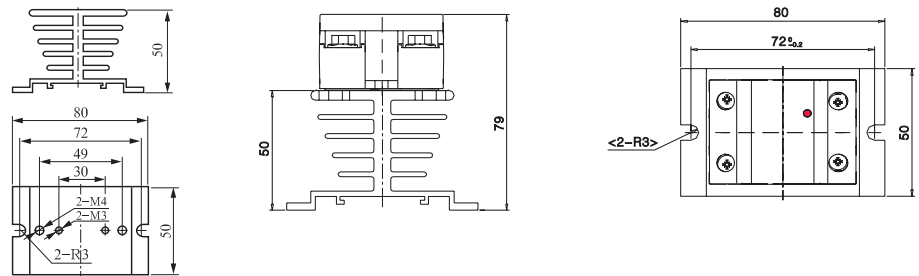

HH-061

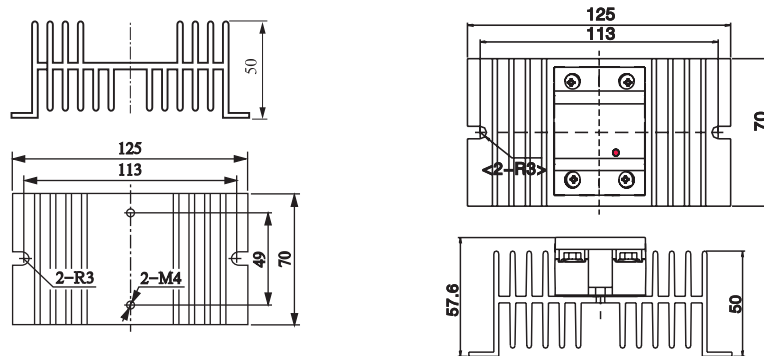

HH-062

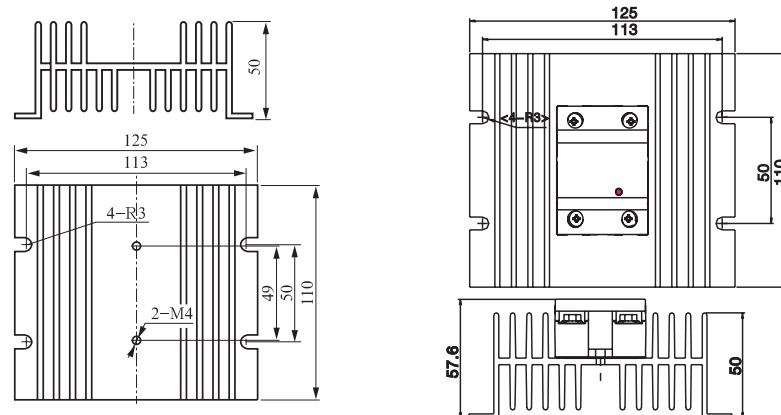

DHS04

