



Industrial & Electrical Components

General Purpose Power Relay

Part No.  
HHC71H



- High-power Relay
- Long life
- High contact load

**CONTACT**

Arrangement	1A/B/C
Contact Material	Silver Alloy
Contact Resistive	Max.: 100 mΩ
Rating	
Resistive load (cosφ=1)	40A 240VAC/28VDC 50A 240VAC/28VDC
Max. Switching Voltage	250VAC
Max. Breaking Capacity	12500VA
Expected life	
Mechanical	1×10 <sup>7</sup>
Electrical	1×10 <sup>5</sup>

**CHARACTERISTICS**

Operate Time	25msec. Max.
Release Time	15msec. Max.
Initial breakdown voltage	
Between Coil & Contact	2500VAC (50/60Hz) for 1 min.
Between Open Contacts	1500VAC (50/60Hz) for 1 min.
Insulation Resistance	Min.500MΩ (500 VDC)
Shock: Endurance	10G
Damage	100G
Vibration: Endurance	10 to 55Hz, 1.0mm D.A.
Damage	10 to 55Hz, 1.0mm D.A.
Ambient temperature	-25℃ ~ +55℃
Unit weight	110g

**ORDERING INFORMATION**

e.g

**HHC71H - 1C - 12D**

①                      ②                      ③

- ① Part No.
- ② Contact arrangement:  
1C=1C/O  
1A=1N/O
- ③ Coil Voltage: 12D=12VDC

**COIL DATA (at 20°C)**

Rated Voltage	Pick-up Voltage VDC (Max)	Drop-out Voltage VDC (Min)	Coil Resistance (Ω) ± 10%	Nominal operating Power	Max.Allowable Voltage (VDC)
12VDC	9.00	1.20	72.00	2W	110% of nominal voltage
24VDC	18.00	2.40	288.00		
48VDC	36.00	4.80	1152.00		
110VDC	82.50	11.00	6050.00		
12VAC	9.60	3.60	12.60	4VA	
24VAC	19.20	7.20	50.40		
48VAC	38.40	14.40	201.60		
220VAC	176.00	66.00	4235.00		

**DIMENSIONS**

Unit: mm

With flange cover

Without cover or with plain cover

SPDT

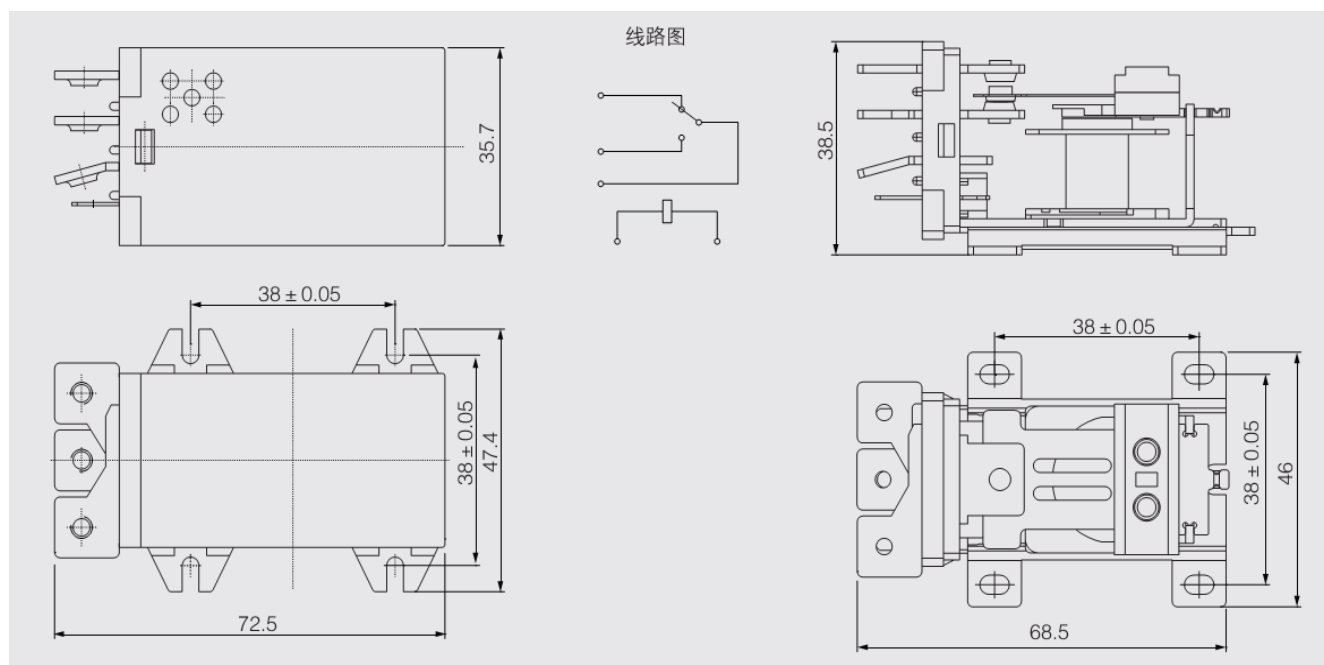

**REFERENCE CURVE**

