

# Federal 3535 7 Series Datasheet

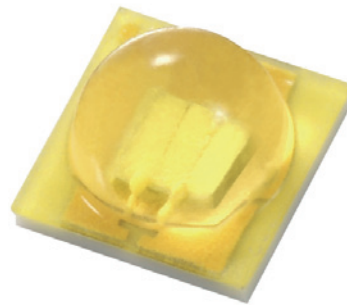

## Features :

- High lumen/lux performance
- Field angle: 100°
- Promising lumen maintenance characteristics
- High efficiency package
- Level 1 on JEDEC moisture sensitivity analysis
- Max pulse current :1,000mA
- RoHS compliant

## Typical Applications :

- Reading lights
- Portable flashlight
- Up-lights and Down-lights
- LCD Backlights
- General lighting
- Contour lights
- Ceiling lights
- Garden lighting



Lighting Design Manufacturing Service

## Table of Contents

---

General Information .....	3
Introduction.....	3
Product Nomenclature .....	3
Mechanical Dimensions.....	4
Circuit.....	4
PCB Layout.....	4
Solder Pad.....	5
Absolute Maximum Ratings .....	5
Luminous Flux Characteristic.....	6
Characteristics .....	7
Optical Characteristics .....	7
Electrical Characteristics .....	7
JEDEC Moisture Sensitivity.....	7
Characteristic Curve .....	8
Spectrum .....	8
Luminous Flux & Junction Temperature.....	8
Radiation Diagram .....	8
CCT & Junction Temperature.....	8
Forward Voltage & Forward Current.....	9
CCT & Forward Current.....	9
Luminous Flux & Forward Current.....	9
Revision History .....	10
About Edison Opto .....	10



Lighting Design Manufacturing Service

## General Information

### Introduction

Federal 3535 is a surface mount, compact, high brightness LED that is built for various illumination needs. A single Cool White Federal 3535 can deliver typical luminous flux of 110 lm while driving at 350mA suitable for any kind of lighting sources, including general illumination, flashlights, streetlights, spotlights, industrial and commercial lightings. The small physical dimension can free customers from any constraints or limitations in these fields of applications. Furthermore, the reflow-solderable nature of Federal 3535 provides an easy path towards the optimum thermal management to achieve a promising reliability. In conclusion, Federal 3535 offers you an extraordinary LED experience.

### Product Nomenclature

The following table describes the available color, power, and lens type. For more flux and forward voltage information, please consult the Bin Group document.

**E F   E W - 1 B E 7**

X1      X2 X3      X4 X5 X6 X7

X1 LED Item		X2 Module		X3 Emitting Color		X4 Power		X5 Lens Item	
Code	Type	Code	Type	Code	Type	Code	Type	Code	Type
EF	Edixeon®Federal	E	Emitter	W	Cool White	1	350mA	B	3.5mmx3.5mm
		S	Star	H	Neutral White				
				X	Warm White				

X6 Housing Item		X7 Serial No.	
Code	Type		
E	E-type		

Figure 1 . Federal 3535 Nomenclature

## Mechanical Dimensions

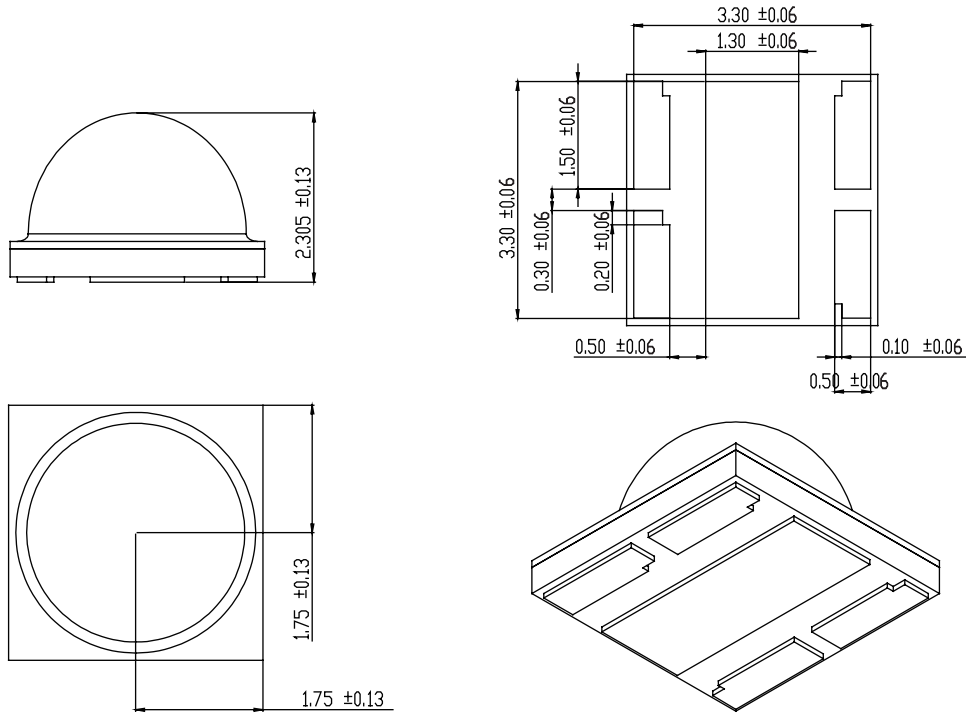
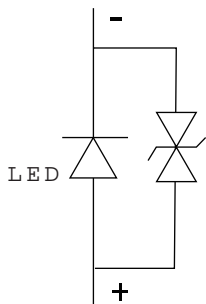

Figure 2. Federal 3535 series Dimension

Notes:

1. All dimensions are measured in mm.
2. Drawings are not to scale.

### Circuit



### PCB Layout

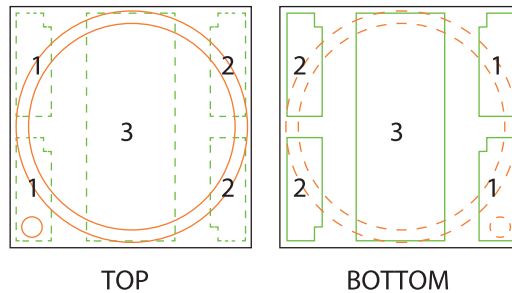

PAD	FUNCTION
1	ANODE
2	CATHODE
3	THERMAL

Figure 3. Pad Configuration

Figure 3. Federal 3535 series circuit and pcb layout

Note:

The thermal pad is electrically isolated from anode and cathode.

## Solder Pad

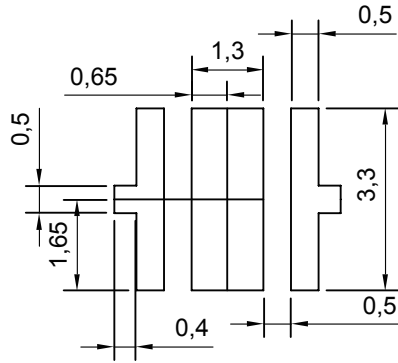

Figure 4. Federal 3535 series solder pad

## Absolute Maximum Ratings

The following tables describe flux of Federal 3535 series under various current and different color.

Table 1. Federal 3535 series absolute maximum ratings

Parameter	Symbol	Value	Units
DC Forward Current <sup>[1]</sup>	$I_F$	350 / 700	mA
Peak Pulsed Current; ( $t_p \leq 100\mu s$ , Duty cycle=0.25)	$I_{pulse}$	1,000	mA
Transient Surge Voltage		8	V
Reverse Voltage <sup>[2]</sup>	$V_R$	Note 2	V
LED Junction Temperature <sup>[3]</sup>	$T_J$	150	°C
Operating Temperature		-40 ~ +80	°C
Storage Temperature		-40 ~ +120	°C
ESD Sensitivity		8,000	V
Allowable Reflow Cycles		3	cycles
Soldering Temperature		260	°C

Notes:

1. Maximum forward current for 1W and 3W are 350mA and 700mA respectively.
2. LEDs are not designed to drive in reverse bias.
3. Proper current derating must be observed to maintain junction temperature below the maximum.



Lighting Design Manufacturing Service

## Luminous Flux Characteristic

The following tables describe flux of Federal 3535 series under various current and different color.

Table 2. Luminous Flux Characteristics,  $I_f=350\text{mA}$  and Thermal Pad= $25^\circ\text{C}$

Power Consumption	Part Name	Color	Forward Current	Min Luminous Flux		Units
				Group	Flux	
1W	EFEW-1BE7	Cool White	350	U3	100	lm
				V1	112.5	
	EFEH-1BE7	Neutral White	350	T3	80	lm
				U1	86.5	
				U2	90	
	EFEX-1BE7	Warm White	350	T2	70	lm
				T3	80	
				U1	86.5	
				U2	90	

Note:

The luminous flux performance is guaranteed within published operating conditions. Edison maintains a tolerance of  $\pm 10\%$  on flux measurements.

## Characteristics

### Optical Characteristics

Table 3. Optical characteristics,  $T_j=25^{\circ}\text{C}$  at 350mA and 700mA

Power Consumption	Part Name	Color	CCT/Wavelength (K)			CRI	Viewing Angle (Degree)
			Min.	Typ.	Max.		
1W / 3W	EFEW-1BE7	Cool White	5,000	--	10,000	70	100
	EFEH-1BE7	Neutral White	3,800	--	50,00	75	100
	EFEY-1BE7	Warm White	2,670	--	3,800	80	100

Notes:

1. Wavelengths are stated as peak wavelength.
2. Edison maintains a tolerance of  $\pm 0.5\text{nm}$  for dominant wavelength,  $\pm 2\text{nm}$  for peak wavelength and  $\pm 5\%$  on CCT measurement.

### Electrical Characteristics

Table 4. Electrical characteristics at  $T_j=25^{\circ}\text{C}$

Power Consumption	Part Name	Color	$V_f$ (V)			Forward Current $I_f$ (mA)	Thermal Resistance ( $^{\circ}\text{C}/\text{W}$ )
			Min.	Typ.	Max.		
1W	EFEW-1BE7	Cool White	3.0	3.4	3.7	350	9
	EFEH-1BE7	Neutral White	3.0	3.4	3.7	350	9
	EFEY-1BE7	Warm White	3.0	3.4	3.7	350	9

Note:

Edison maintains a tolerance of 0.06V on forward voltage measurement.

### JEDEC Moisture Sensitivity

Table 5. JEDEC Moisture Sensitivity

Level	Floor Life		Soak Requirements	
	Time	Conditions	Standard	
			Time (hours)	Conditions
1	unlimited	$\leq 30^{\circ}\text{C} / 85\% \text{RH}$	168+5/-0	$85^{\circ}\text{C} / 85\% \text{RH}$

## Characteristic Curve

### Spectrum

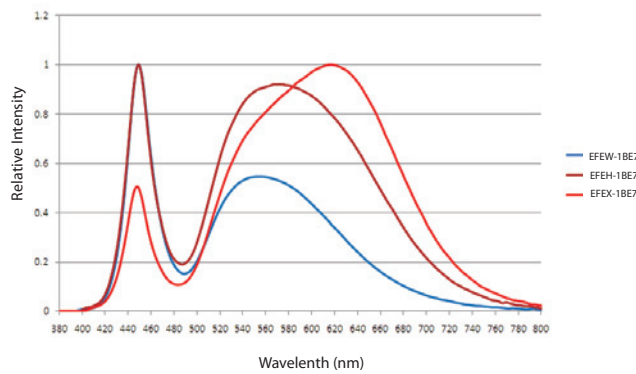

Figure 5. Color Spectrum for White series at  $T_j=25\text{ }^\circ\text{C}$

### Radiation Diagram

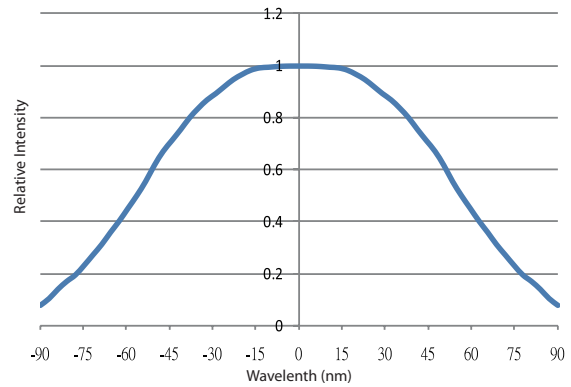

Figure 6. Radiation diagram

### Luminous Flux & Junction Temperature

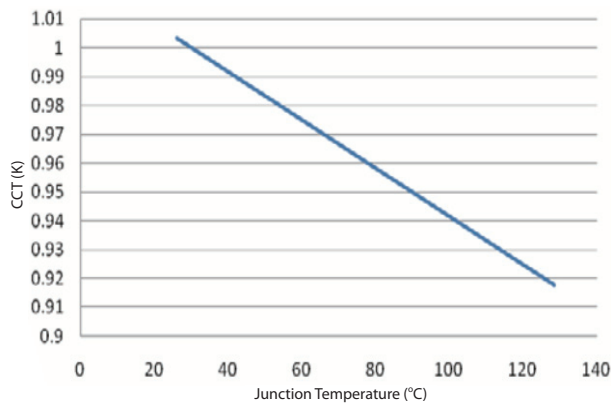

Figure 7. Relative luminous flux vs. junction temperature for White series.

### CCT & Junction Temperature

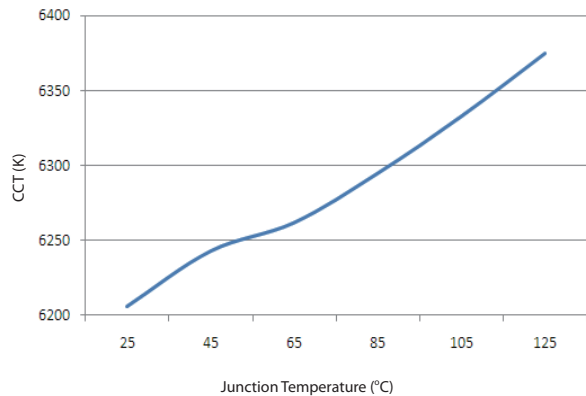

Figure 8. Typical CCT vs. junction temperature for Cool White.

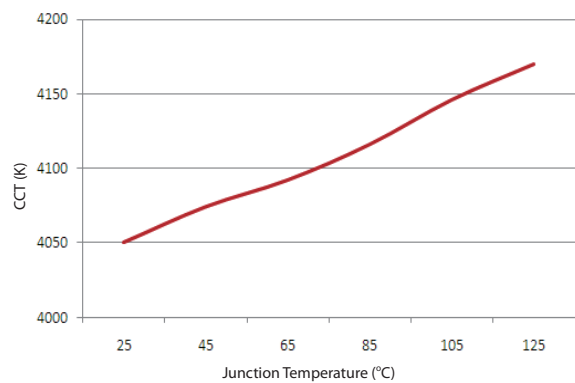

Figure 9. Typical CCT vs. junction temperature for Neutral White

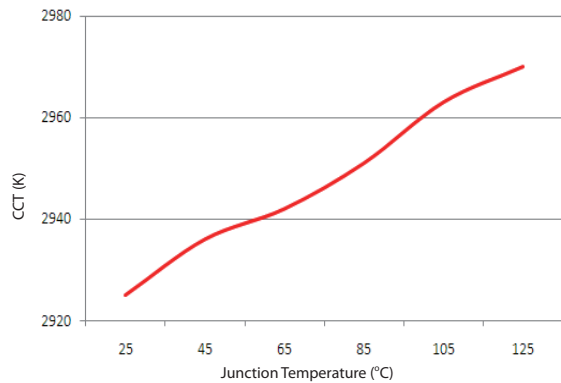

Figure 10. Typical CCT vs. junction temperature for Warm White



### Forward Voltage & Forward Current

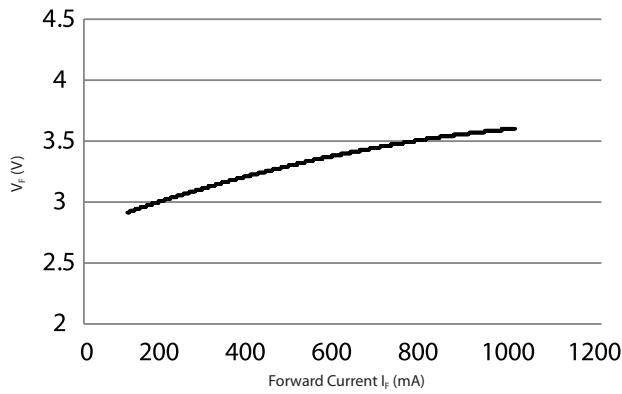

Figure 11. Forward voltage vs. forward current for Cool White, Neutral White and Warm White

### Luminous Flux & Forward Current

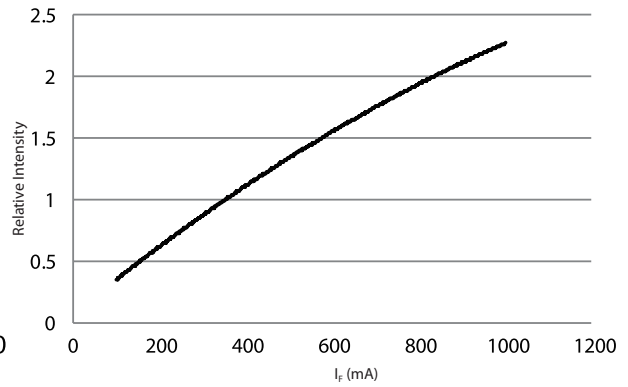

Figure 12. Relative luminous flux vs. forward current for Cool White

### CCT & Forward Current

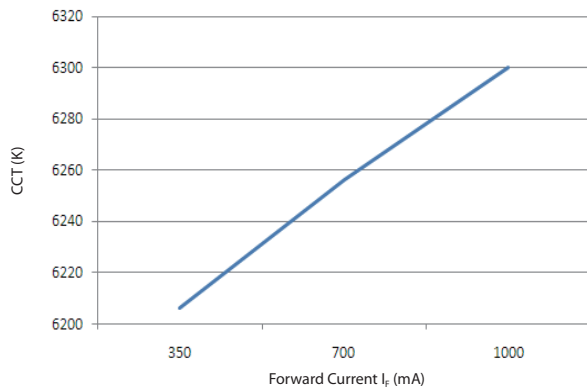

Figure 13. CCT vs. forward current for Cool White.

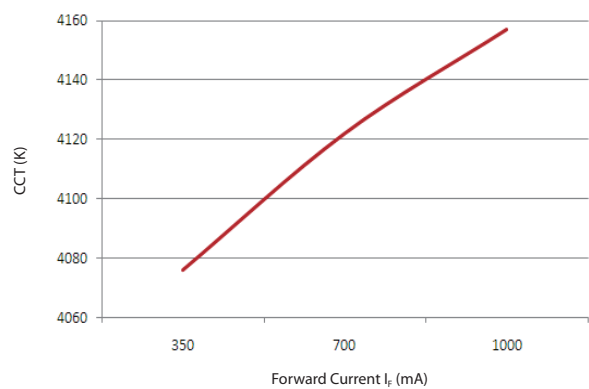

Figure 14. CCT vs. forward current for Neutral White.

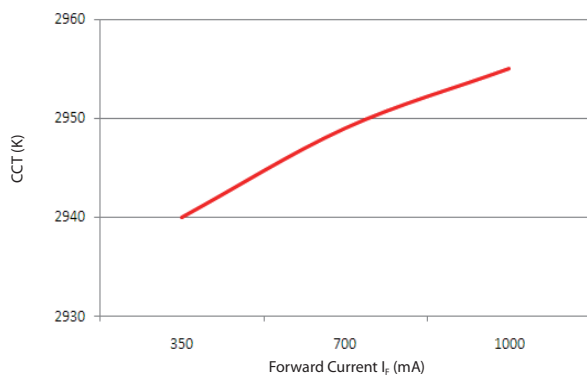

Figure 15. CCT vs. forward current for Warm White.



Lighting Design Manufacturing Service

## Revision History

Table 6. Revision history of Federal 3535 7 series datasheet

Version	Description	Release Date
1	Establish datasheet	2011.04.20
2	1.Update the dimensions 2. Update the luminous flux with bin group 3. Update the voltage of electrical characteristics	2011.07.16

## About Edison Opto

Edison Opto is a leading manufacturer of high power LED and a solution provider experienced in LDMS. LDMS is an integrated program derived from the four essential technologies in LED lighting applications- Thermal Management, Electrical Scheme, Mechanical Refinement, Optical Optimization, to provide customer with various LED components and modules. More Information about the company and our products can be found at [www.edison-opto.com](http://www.edison-opto.com)

Copyright©2011 Edison Opto. All rights reserved. No part of publication may be reproduced or transmitted in any form or by any means, electronic or mechanical, including photo copy, recording or any other information storage and retrieval system, without prior permission in writing from the publisher. The information in this publication are subject to change without notice.

[www.edison-opto.com](http://www.edison-opto.com)

For general assistance please contact:  
[service@edison-opto.com.tw](mailto:service@edison-opto.com.tw)

For technical assistance please contact:  
[LED.Detective@edison-opto.com.tw](mailto:LED.Detective@edison-opto.com.tw)