

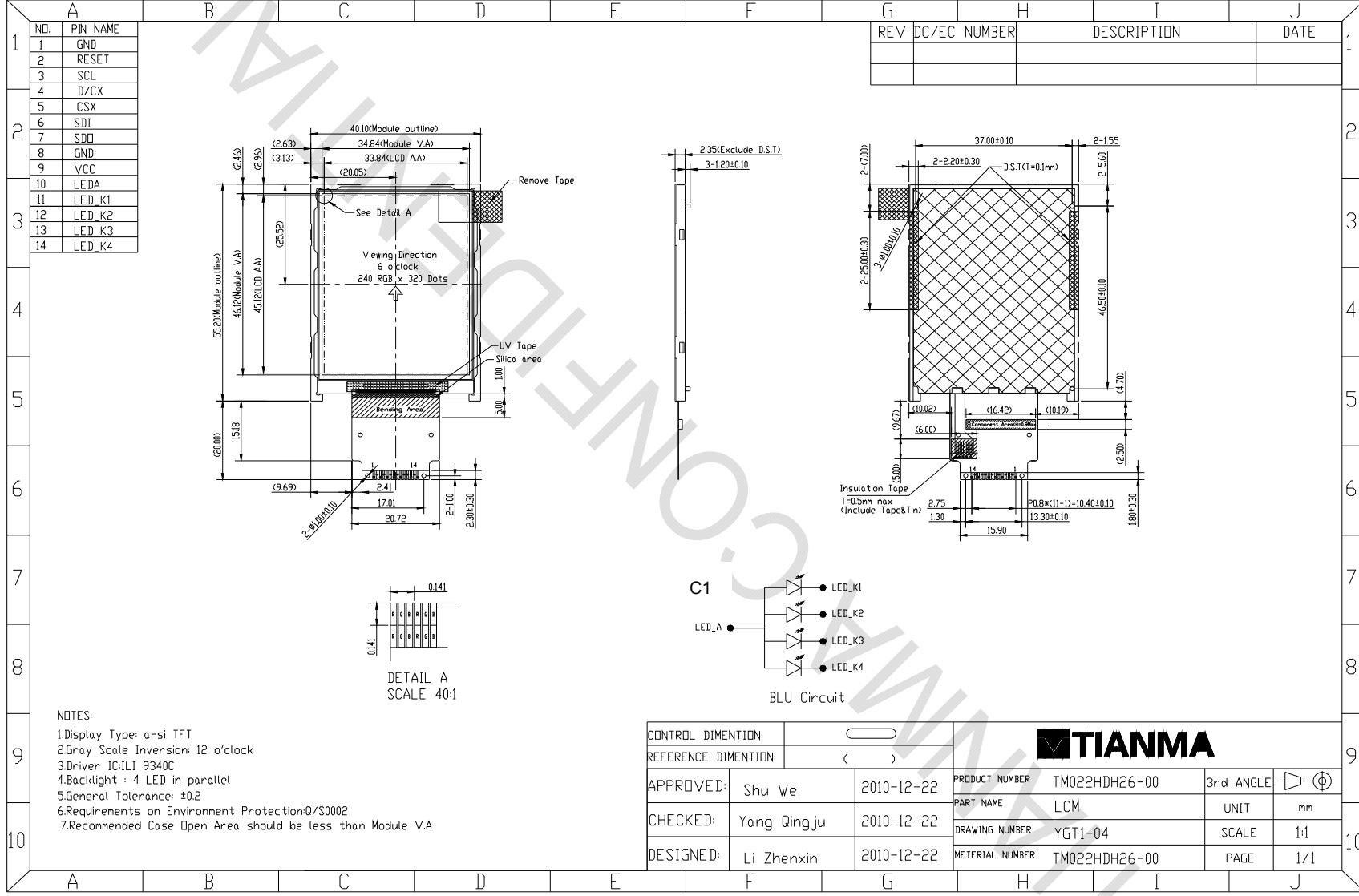

8 Mechanical And FPCA Drawing



The information contained herein is the exclusive property of SHANGHAI TIANMA MICRO-ELECTRONICS Corporation, and shall not be distributed, reproduced, or disclosed in whole or in part without prior written permission of SHANGHAI TIANMA MICRO-ELECTRONICS Corporation.



1 General Specifications

Feature		Spec
Display Spec.	Size	2.2 inch
	Resolution	240(RGB) x 320
	Interface	4-Wire SPI
	Color Depth	262K/65K
	Technology Type	a-Si
	Pixel Pitch (mm)	0.141X0.141
	Pixel Configuration	R.G.B. Vertical Stripe
	Display Mode	TM with Normally White
	Surface Treatment(Up Polarizer)	Clear Type(3H)
	Viewing Direction	6 o'clock
	Gray Scale Inversion Direction	12 o'clock
Mechanical Characteristics	LCM (W x H x D) (mm)	40.10x55.20x2.35
	Active Area(mm)	33.84x45.12
	With/Without TSP	Without TSP
	Weight (g)	TBD
	LED Numbers	4 LEDs
Electronic	Driver IC	ILI9340C

Note 1: Viewing direction for best image quality is different from TFT definition, there is a 180 degree shift.

Note 2: Requirements on Environmental Protection: Q/S0002

Note 3: LCM weight tolerance: +/- 5%



2 Input/Output Terminals

2.1 TFT LCD Panel

No	Symbol	I/O	Description	Comment
1	GND	P	Power Ground	
2	RESET	I	Reset Signal	
3	SCL	I	Serial interface clock in 4-wire 8-bit serial data interface	
4	D/CX	I	Command or parameter select in 4-wire 8-bit serial data interface	
5	CS	I	Chip select signal	
6	SDI	I	Serial input signal	
7	SDO	O	Serial output signal	
8	GND	P	Power Ground	
9	VCC	P	Power Supply of Analog/Logic Circuit	
10	LEDA	P	LED anode	
11	LEDK1	P	LED cathode	
12	LEDK2	P	LED cathode	
13	LEDK3	P	LED cathode	
14	LEDK4	P	LED cathode	

Note1: I/O definition:

I----Input O---Output P----Power/Ground NC--- Not connected



3 Absolute Maximum Ratings

3.1 Driving TFT LCD Panel

Ta = 25°C

Item	Symbol	MIN	MAX	Unit	Remark
Logic Supply Voltage	VCC	-0.3	4.6	V	
Analog Supply Voltage	VCC	-0.3	4.6	V	
Input voltage	CS/D/CX/SCL/SDI /RESET	-0.3	IOVCC+0.5	V	
Back Light Forward Current	I _F	-	25	mA	ONE LED
Operating Temperature	Top	-20	70	°C	
Storage Temperature	Tst	-30	80	°C	



4 Electrical Characteristics

4.1 Driving TFT LCD Panel

GND=0V, Ta=25°C

Item	Symbol	MIN	TYP	MAX	Unit	Remark
Logic Supply Voltage	VCC	1.65	2.8	3.3	V	
Analog Supply Voltage	VCC	2.3	2.8	3.3	V	
Input Signal Voltage	High Level	VIH	0.7 VCC	-	VCC	V
	Low Level	VIL	-	-	0.3 VCC	V
Output Signal Voltage	High Level	VOH	0.8 VCC	-	-	V
	Low Level	VOL	-	-	0.2 VCC	V
(Panel+LSI) Power Consumption	Black Mode	-	18.10	-	m W	
	8 color Mode	-	8.16	-	m W	
	Sleeping Mode	-	0.035	-	m W	

4.2 Driving Backlight Ta=25°C

Item	Symbol	Min	Typ	Max	Unit	Remark
Forward Current	I _F	--	15	25	mA	For each LED
Forward Voltage	V _F	(2.9)	3.2	(3.4)	V	4 LEDs (in parallel)
Power Consumption	W _{BL}	--	192	--	mW	

Note1: Figure below shows the connection of backlight LED.

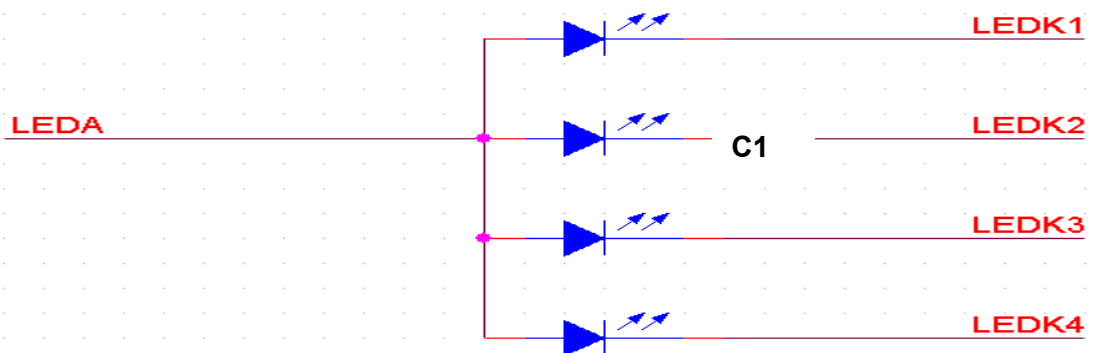

Note 2: One LED: I_F =15 mA, V_F =3.2V

Note 3: The Minimum Life of LED: 20,000 hours



4.3 Block Diagram

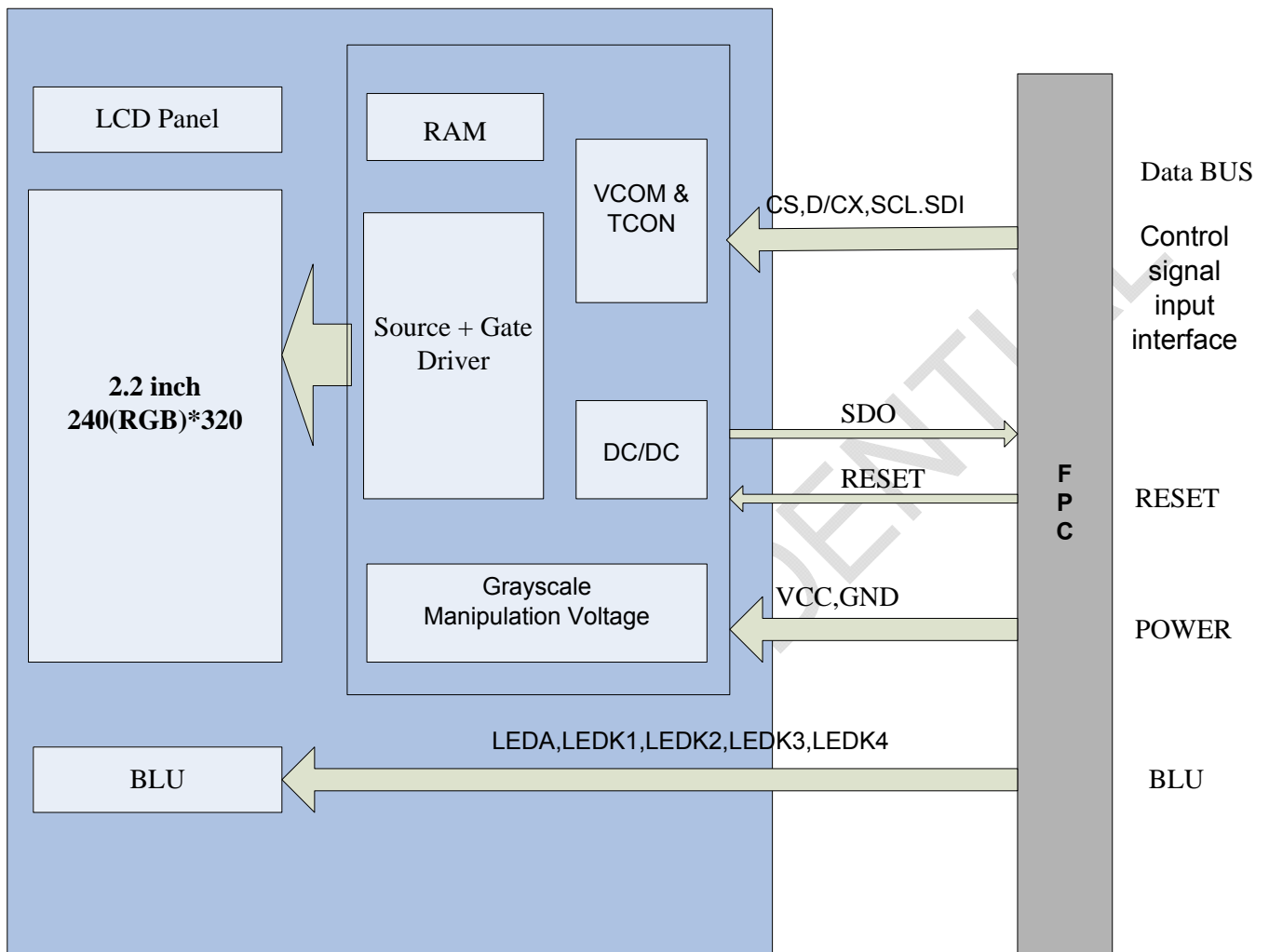



5 Timing Chart

5.1 Timing Parameter

Ta=25°C

Signal	Symbol	Parameter	min	max	Unit	Description
CS	tcss	Chip select time (Write)	40	-	ns	
	tcsh	Chip select hold time (Read)	40	-	ns	
SCL	twc	Serial clock cycle (Write)	100	-	ns	
	twrh	SCL "H" pulse width (Write)	40	-	ns	
	twrl	SCL "L" pulse width (Write)	40	-	ns	
	trc	Serial clock cycle (Read)	150	-	ns	
	trdh	SCL "H" pulse width (Read)	60	-	ns	
	trdl	SCL "L" pulse width (Read)	60	-	ns	
D/CX	tas	D/CX setup time	10	-		
	tah	D/CX hold time (Write / Read)	10	-		
SDA / SDI (Input)	tds	Data setup time (Write)	30	-	ns	
	tdh	Data hold time (Write)	30	-	ns	
SDA / SDO (Output)	tacc	Access time (Read)	10	-	ns	For maximum CL=30pF
	tod	Output disable time (Read)	10	50	ns	For minimum CL=8pF

Table 5.0 timing parameter

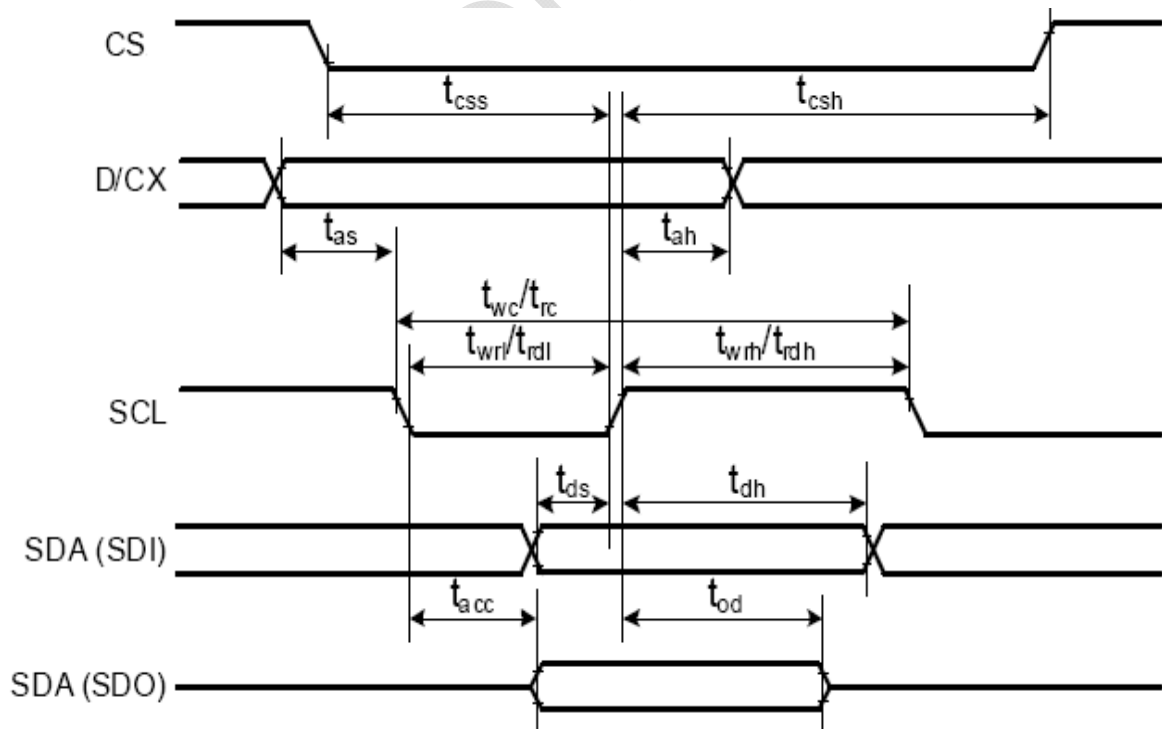

Figure 5.1 Serial interface characteristics

The information contained herein is the exclusive property of SHANGHAI TIANMA MICRO-ELECTRONICS Corporation, and shall not be distributed, reproduced, or disclosed in whole or in part without prior written permission of SHANGHAI TIANMA MICRO-ELECTRONICS Corporation.



5.2 Register write/read timing

a. Write to register

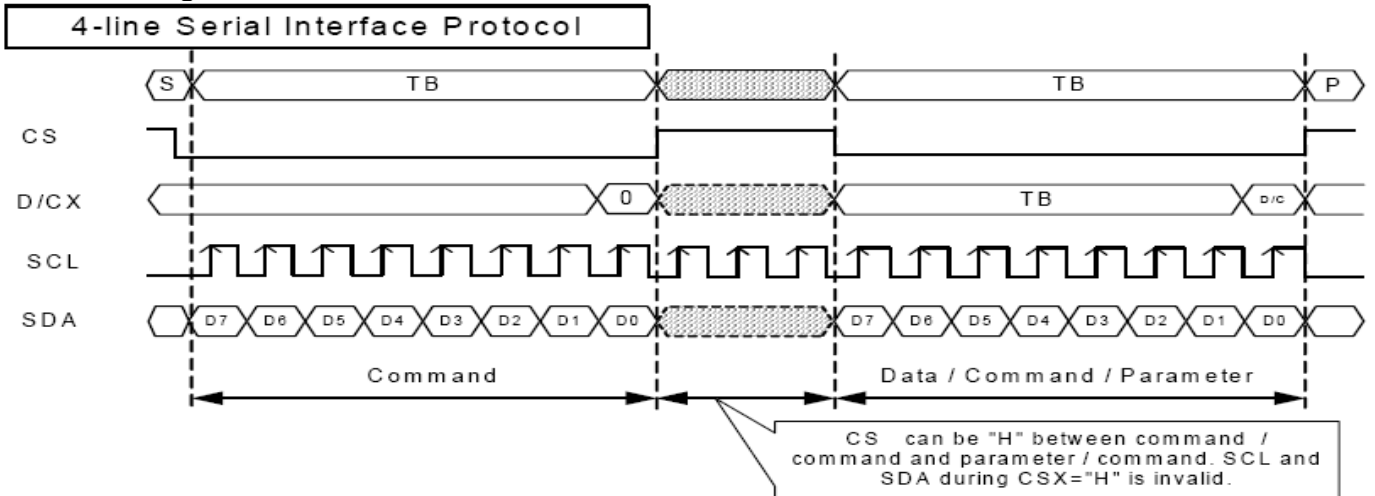

Figure 5.2 Register write timing in serial bus system interface

b. Read from register

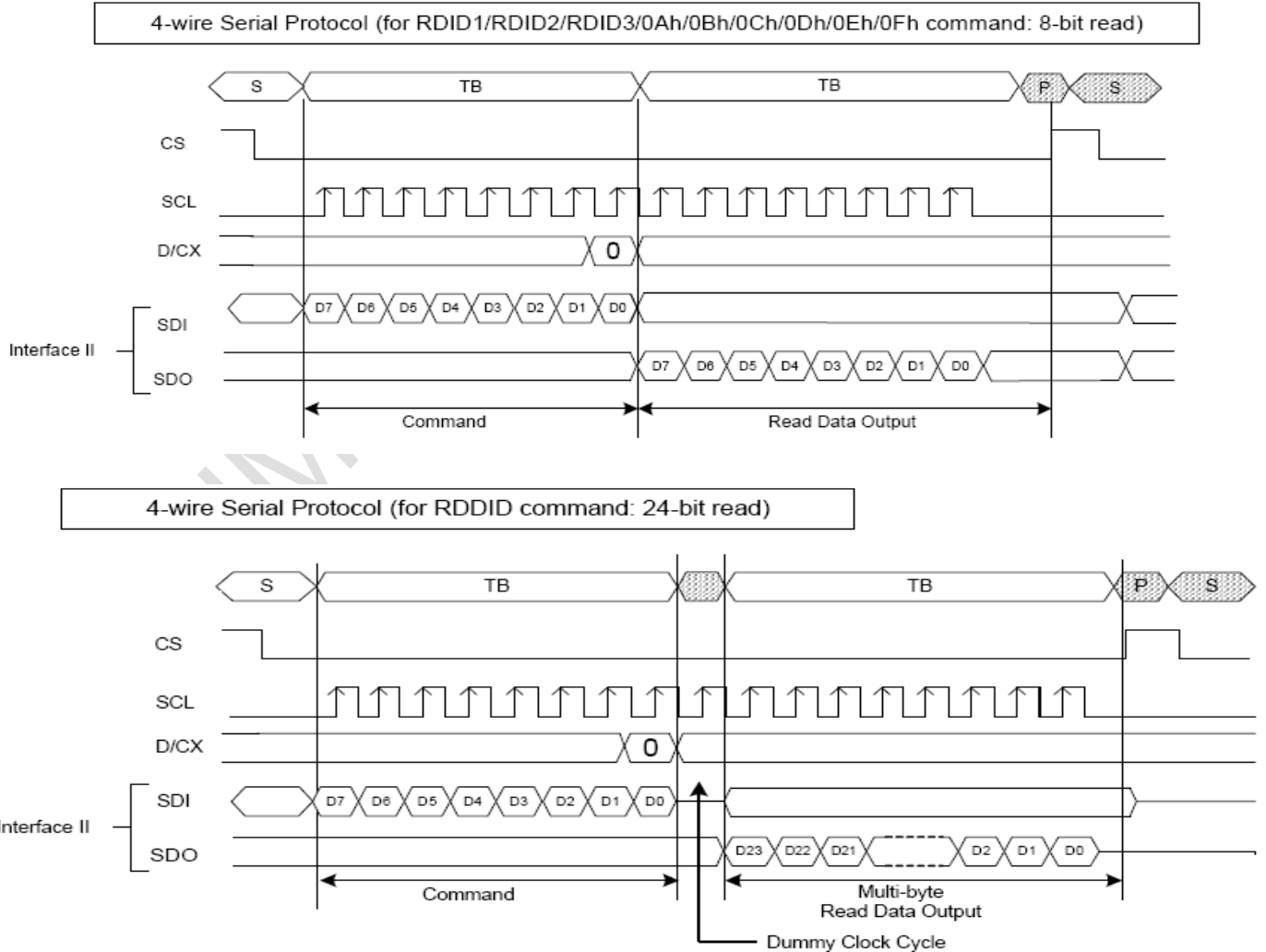

Figure 5.3 Register read timing in serial bus system interface

The information contained herein is the exclusive property of SHANGHAI TIANMA MICRO-ELECTRONICS Corporation, and shall not be distributed, reproduced, or disclosed in whole or in part without prior written permission of SHANGHAI TIANMA MICRO-ELECTRONICS Corporation.



5.3 GRAM Writing Characteristics (565 mode)

16 bit/pixel color order (R:5-bit, G:6-bit, B:5-bit), 65,536 colors

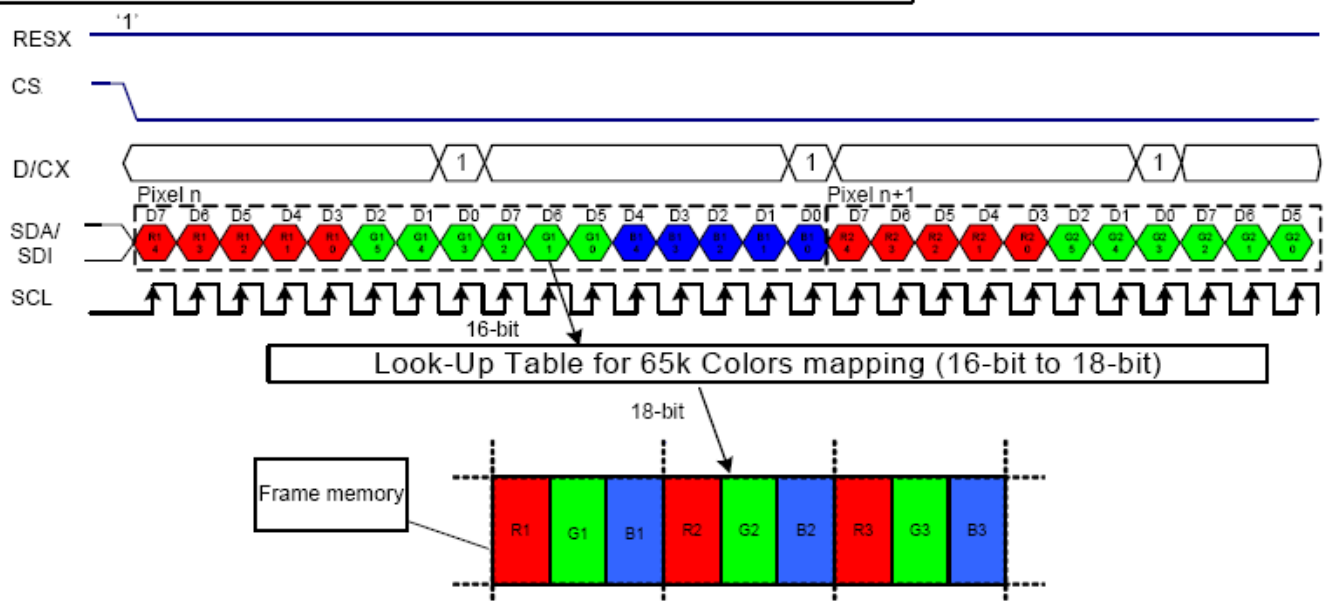

666 mode

18 bit/pixel color order (R:6-bit, G:6-bit, B:6-bit), 262,144 colors

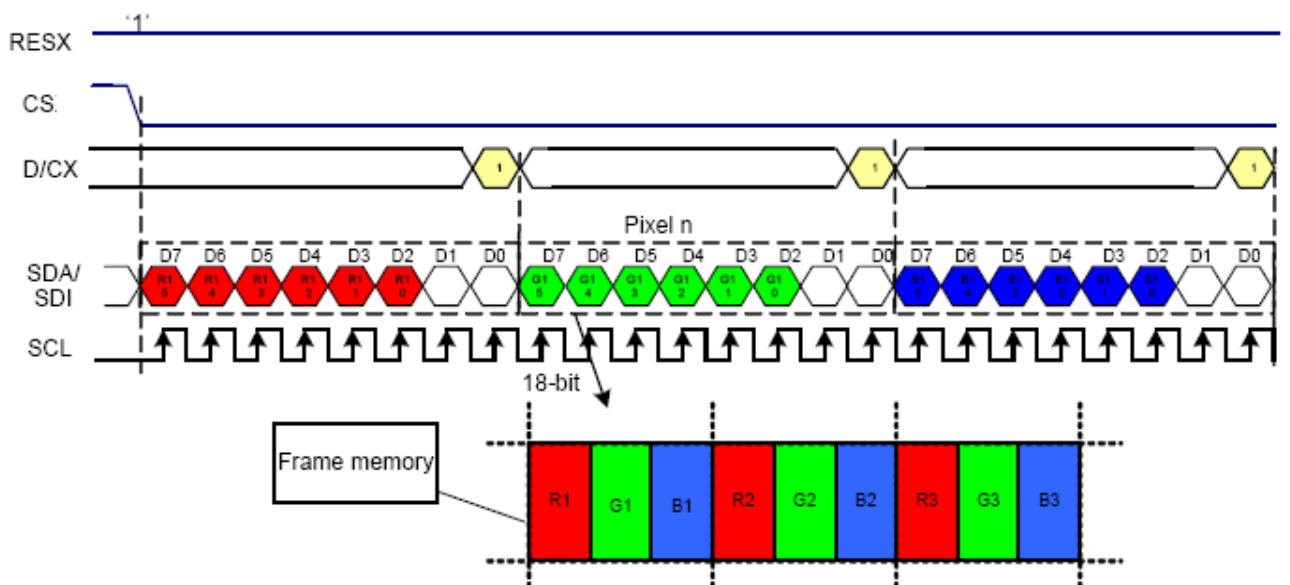
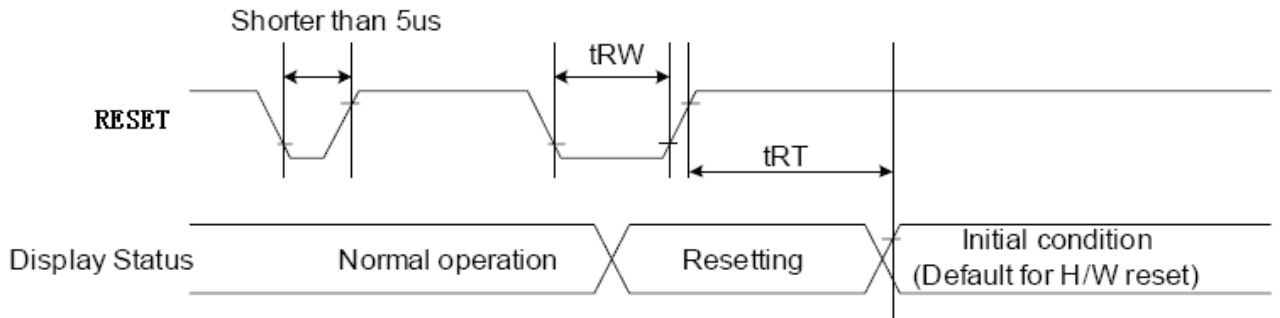

Figure 5.4 GRAM Writing Characteristics for 555/666 mode of 4-Wire SPI



5.4 Reset Timing Characteristics

Ta=25°C



Signal	Symbol	Parameter	Min	Max	Unit
RESET	tRW	Reset pulse duration	10		uS
	tRT	Reset cancel		5 (note 1,5)	mS
				120 (note 1,6,7)	mS

Figure 5.5 RESET Timing

TIANMA CONFIDENTIAL



5.5 Power On/Off sequence

5.5.1 Power on Sequence

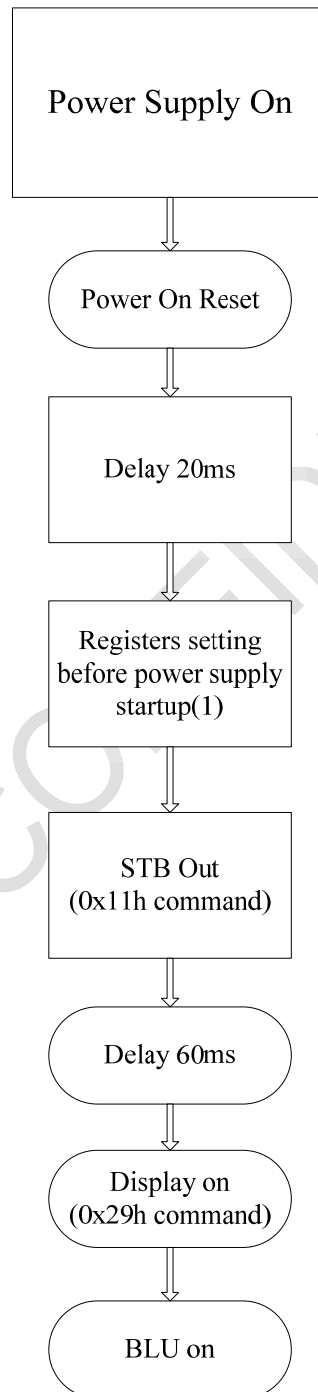

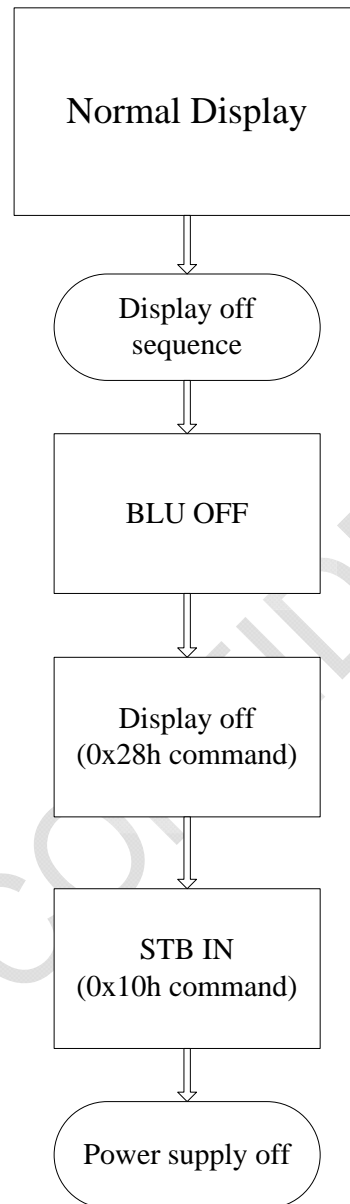



6 Optical Characteristics

Ta=25°C

Item	Symbol	Condition	Min	Typ	Max	Unit	Remark
View Angles	θT	$CR \geq 10$	60	70	-	Degree	Note 2
	θB		50	60	-		
	θL		60	70	-		
	θR		60	70	-		
Contrast Ratio	CR	$\theta=0^\circ$	400	500	-		Note1 Note3
Response Time	T_{ON}	25°C	-	20	30	ms	Note1 Note4
	T_{OFF}						
Chromaticity	White	x	Backlight is on	0.245	0.295	0.345	Note5 Note1
		y		0.274	0.324	0.374	
	Red	x		0.556	0.606	0.656	
		y		0.277	0.327	0.377	
	Green	x		0.294	0.344	0.394	
		y		0.484	0.534	0.584	
	Blue	x		0.096	0.146	0.196	
		y		0.056	0.106	0.156	
Uniformity	U		--	80	--	%	Note1 Note6
NTSC			--	50	--	%	Note 5
Luminance	L		200	240	--	cd/m ²	Note1 Note7

Test Conditions:

- $V_F = 3.2V$, $I_L = 20mA$ (Backlight current), the ambient temperature is 25°C.
- The test systems refer to Note 1 and Note 2.



Note 1: Definition of optical measurement system.

The optical characteristics should be measured in dark room. After 5 minutes operation, the optical properties are measured at the center point of the LCD screen. All input terminals LCD panel must be ground when measuring the center area of the panel.

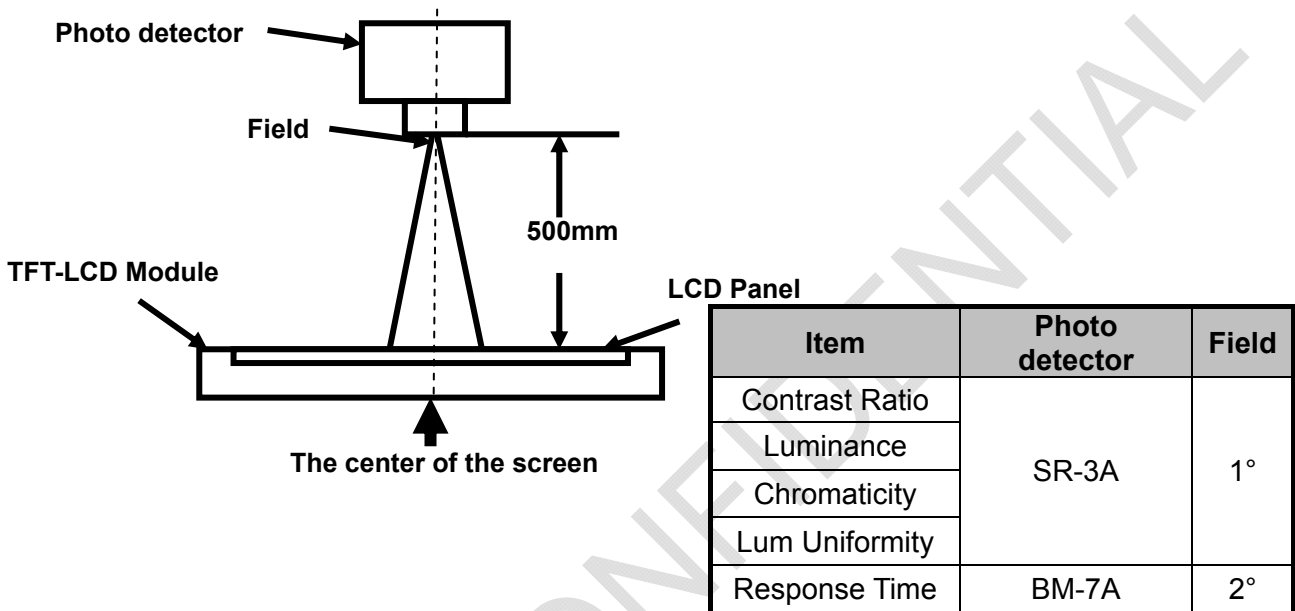

Note 2: Definition of viewing angle range and measurement system.

viewing angle is measured at the center point of the LCD by CONOSCOPE(ergo-80).

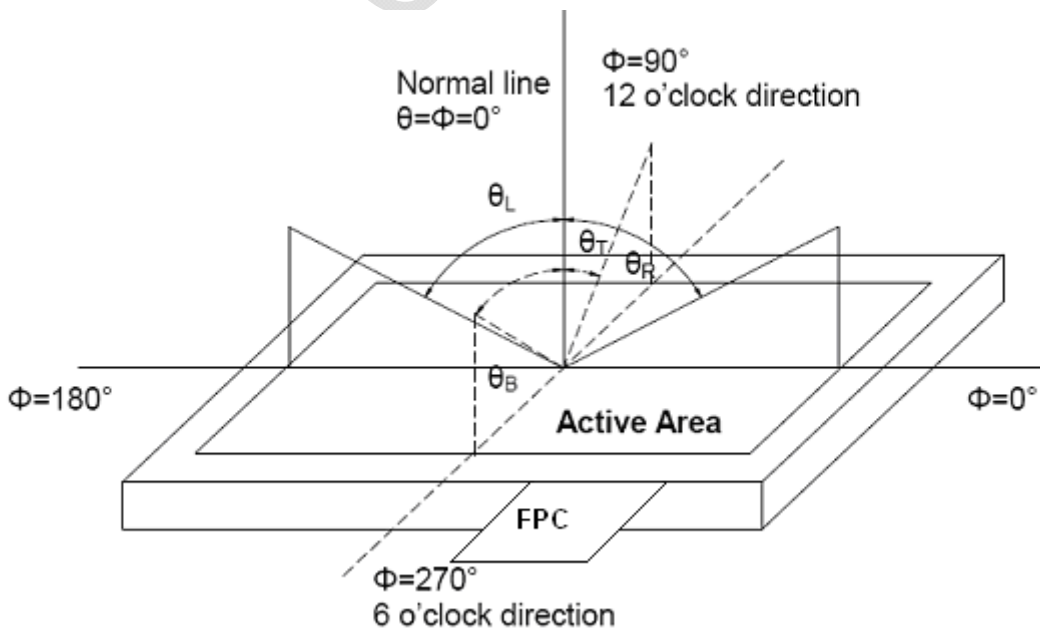

Fig. 1 Definition of viewing angle



Note 3: Definition of contrast ratio

$$\text{Contrast ratio (CR)} = \frac{\text{Luminance measured when LCD is on the "White" state}}{\text{Luminance measured when LCD is on the "Black" state}}$$

"White state ": The state is that the LCD should be driven by V_{white} .

"Black state": The state is that the LCD should be driven by V_{black} .

V_{white} : To be determined V_{black} : To be determined.

Note 4: Definition of Response time

The response time is defined as the LCD optical switching time interval between "White" state and "Black" state. Rise time (T_{ON}) is the time between photo detector output intensity changed from 90% to 10%. And fall time (T_{OFF}) is the time between photo detector output intensity changed from 10% to 90%.

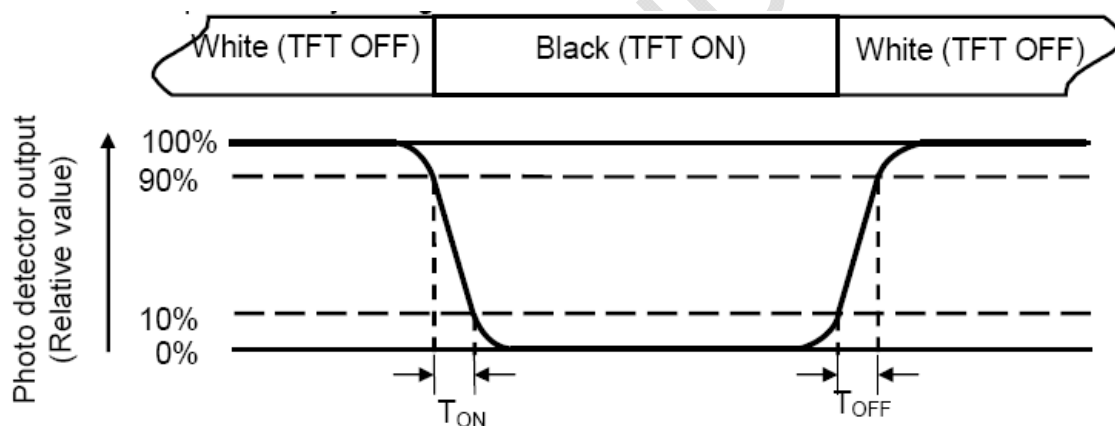

Note 5: Definition of color chromaticity (CIE1931)

Color coordinates measured at center point of LCD.



Note 6: Definition of Luminance Uniformity

Active area is divided into 9 measuring areas (Refer Fig. 2). Every measuring point is placed at the center of each measuring area.

$$\text{Luminance Uniformity (U)} = L_{\min} / L_{\max}$$

L-----Active area length W----- Active area width

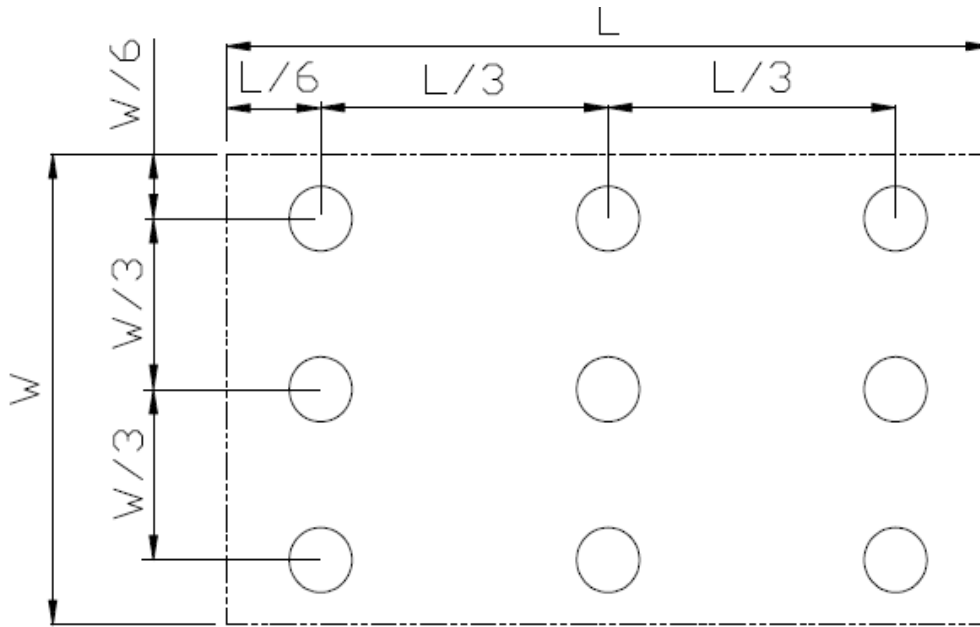

Fig. 2 Definition of uniformity

Lmax: The measured maximum luminance of all measurement position.

Lmin: The measured minimum luminance of all measurement position.

Note 7: Definition of Luminance:

Measure the luminance of white state at center point.



7 Environmental / Reliability Test

No	Test Item	Condition	Remarks
1	High Temperature Operation	Ts=+70℃, 240hrs	Note1 IEC60068-2-1:2007, GB2423.2-2008
2	Low Temperature Operation	Ta=-20℃, 240hrs	IEC60068-2-1:2007 GB2423.1-2008
3	High Temperature Storage	Ta=+80℃, 240hrs	IEC60068-2-1:2007 GB2423.2-2008
4	Low Temperature Storage	Ta=-30℃, 240hrs	IEC60068-2-1:2007 GB2423.1-2008
5	High Temperature & High Humidity Storage	Ta=+60℃, 90% RH 240 hours	Note2 IEC60068-2-78 :2001 GB/T2423.3—2006
6	Thermal Shock (Non-operation)	-30℃ 30 min~+70℃ 30 min, Change time:5min, 20 Cycles	Start with cold temperature, End with high temperature, IEC60068-2-14:1984, GB2423.22-2002
7	Electro Static Discharge (Operation)	C=150pF, R=330Ω, 5points/panel Air:±8KV, 5times; Contact:±4KV, 5 times; (Environment: 15℃~35℃, 30%~60%, 86Kpa~106Kpa)	IEC61000-4-2:2001 GB/T17626.2-2006
8	Vibration (Non-operation)	Frequency range:10~55Hz, Stroke:1.5mm Sweep:10Hz~55Hz~10Hz hours for each direction of X.Y.Z. (6 hours for total) (Package condition)	IEC60068-2-6:1982 GB/T2423.10—1995
9	Shock (Non-operation)	100G 6ms, ±X,±Y,±Z 3times, for each direction	IEC60068-2-27:1987 GB/T2423.5—1995
10	Package Drop Test	Height:80 cm, 1 corner, 3 edges, 6 surfaces	IEC60068-2-32:1990 GB/T2423.8—1995

Note1 : Ts is the temperature of panel's surface.

Note2: Ta is the ambient temperature of sample.

The information contained herein is the exclusive property of SHANGHAI TIANMA MICRO-ELECTRONICS Corporation, and shall not be distributed, reproduced, or disclosed in whole or in part without prior written permission of SHANGHAI TIANMA MICRO-ELECTRONICS Corporation.