



NOMINAL SIZE = 0.87 in x 0.5 in
(22,1 mm x 12,57 mm)

Features

- Up to 6-A Output Current
- 12-V Input Voltage
- Wide-Output Voltage Adjust (1.2 V to 5.5 V)/(0.8 V to 1.8 V)
- Efficiencies up to 93 %
- 200 W/in³ Power Density
- On/Off Inhibit
- Under-Voltage Lockout
- Operating Temp: -40 to +85 °C
- Auto-Track™ Sequencing
- Output Over-Current Protection (Non-Latching, Auto-Reset)
- IPC Lead Free 2
- Safety Agency Approvals: UL 60950, cUL 600950, EN60950 (VDE is Pending)
- Point-of-Load Alliance (POLA) Compatible

Description

The PTH12050 series is the smallest non-isolated power modules from Texas Instruments that features Auto-Track™ Sequencing. Auto-Track simplifies the sequencing of supply voltages in power systems by enabling modules to track each other, or any other external voltage, during power up and power down.

Although small in size (0.87 in × 0.5 in), these modules are rated for up to 6 A of output current, and are an ideal choice in applications where space, performance, and a power-up sequencing capability are important attributes.

The series operates from an input voltage of 12-V to provide step-down conversion to a wide range of output volt-

ages. The output voltage of the W-suffix device may set to any voltage over the adjust range, 1.2 V to 5.5 V. The L-suffix device has an adjustment range of 0.8 V to 1.8 V. The output voltage is set within the adjustment range using a single external resistor.

Other operating features include an on/off inhibit, output voltage adjust (trim), and output over-current protection. For high efficiency these parts employ a synchronous rectifier output stage.

Target applications include telecom, industrial, and general purpose circuits, including low-power dual-voltage systems that use a DSP, microprocessor, ASIC, or FPGA.

Pin Configuration

Pin	Function
1	GND
2	Track
3	V _{in}
4	Inhibit*
5	V _o Adjust
6	V _{out}

* Denotes negative logic:
Open = Normal operation
Ground = Function active



Standard Application

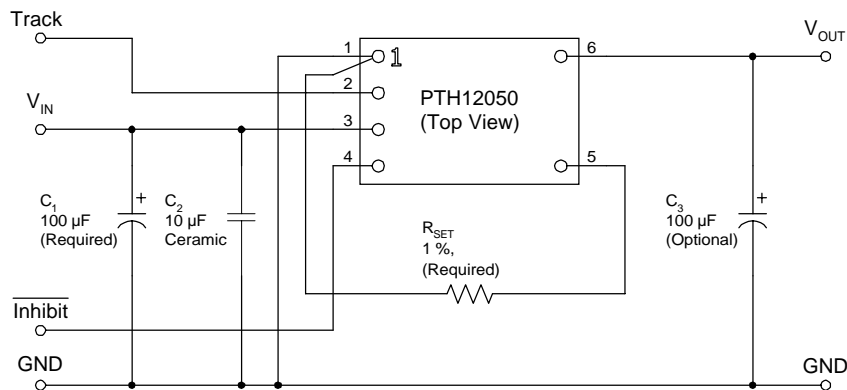

- R_{set} = Required to set the output voltage higher than the lowest value. (See spec. table for values)
- C₁ = Required 100 µF capacitor
- C₂ = 10 µF ceramic capacitor. Required for output voltages 3.3 V and higher
- C₃ = Optional 100 µF capacitor

Ordering Information

Output Voltage (PTH12050□xx)		Package Options (PTH12050x□□) ⁽¹⁾		
Code	Voltage	Code	Description	Pkg Ref. ⁽²⁾
W	1.2 V – 5.5 V (Adjust)	AH	Horiz. T/H	(EUV)
L	0.8 V – 1.8 V (adjust)	AS	SMD, Standard ⁽³⁾	(EUV)

- Notes:** (1) Add “T” to end of part number for tape and reel on SMD packages only.
 (2) Reference the applicable package reference drawing for the dimensions and PC board layout
 (3) “Standard” option specifies 63/37, Sn/Pb pin solder material.

Pin Descriptions

Vin: The positive input voltage power node to the module, which is referenced to common *GND*.

Vout: The regulated positive power output with respect to the *GND* node.

GND: This is the common ground connection for the *Vin* and *Vout* power connections. It is also the 0 VDC reference for the control inputs.

Vo Adjust: A 1 % resistor must be directly connected between this pin and *GND* (pin 1) to set the output voltage of the module to a value higher than its lowest value. The temperature stability of the resistor should be 100 ppm/°C (or better). The set-point range is 1.2 V to 5.5 V for W-suffix devices, and 0.8 V to 1.8 V for L-suffix devices. The resistor value required for a given output voltage may be calculated using a formula. If left open circuit, the output voltage will default to its lowest value. For further information on output voltage adjustment consult the related application note.

The specification table gives the preferred resistor values for a number of standard output voltages.

Inhibit: The Inhibit pin is an open-collector/drain negative logic input that is referenced to *GND*. Applying a low-level ground signal to this input disables the module’s output and turns off the output voltage. When the *Inhibit* control is active, the input current drawn by the regulator is significantly reduced. If the *Inhibit* pin is left open-circuit, the module will produce an output whenever a valid input source is applied.

Track: This is an analog control input that enables the output voltage to follow an external voltage. This pin becomes active typically 20 ms after the input voltage has been applied, and allows direct control of the output voltage from 0 V up to the nominal set-point voltage. Within this range the output will follow the voltage at the *Track* pin on a volt-for-volt basis. When the control voltage is raised above this range, the module regulates at its set-point voltage. The feature allows the output voltage to rise simultaneously with other modules powered from the same input bus. If unused, the input should be connected to *Vin*. *Note: Due to the under-voltage lockout feature, the output of the module cannot follow its own input voltage during power up. For more information, consult the related application note.*

Environmental & Absolute Maximum Ratings (Voltages are with respect to GND)

Characteristics	Symbols	Conditions	Min	Typ	Max	Units
Track Input Voltage	V_{track}		-0.3	—	$V_{in} + 0.3$	V
Operating Temperature Range	T_a	Over V_{in} Range	-40	—	85	°C
Solder Reflow Temperature	T_{reflow}	Surface temperature of module body or pins			235 ⁽ⁱ⁾	°C
Storage Temperature	T_s	—	-40	—	125	°C
Mechanical Shock		Per Mil-STD-883D, Method 2002.3 1 msec, ½ Sine, mounted	—	500	—	G’s
Mechanical Vibration		Mil-STD-883D, Method 2007.2 20-2000 Hz	—	20	—	G’s
Weight	—		—	2.9	—	grams
Flammability	—	Meets UL 94V-O				

- Notes:** (i) During reflow of SMD package version do not elevate peak temperature of the module, pins or internal components above the stated maximum.

Specifications (Unless otherwise stated, $T_a = 25^\circ\text{C}$, $V_{in} = 12\text{ V}$, $V_{out} = 3.3\text{ V}$, $C_1 = 100\ \mu\text{F}$, $C_2 = 10\ \mu\text{F}$, $C_3 = 0\ \mu\text{F}$, and $I_o = I_{o,max}$)

Characteristics	Symbols	Conditions	PTH12050W			Units	
			Min	Typ	Max		
Output Current	I_o	Over ΔV_{adj} range 85 °C, 400 LFM airflow 60 °C, natural convection	0 0	— —	6 6	⁽¹⁾ ⁽¹⁾ A	
Input Voltage Range	V_{in}	Over I_o range	10.8	—	13.2	V	
Set-Point Voltage Tolerance	$V_o\text{ tol}$		—	—	± 2	⁽²⁾ % V_o	
Temperature Variation	ΔReg_{temp}	$-40^\circ\text{C} < T_a < +85^\circ\text{C}$	—	± 0.5	—	% V_o	
Line Regulation	ΔReg_{line}	Over V_{in} range	—	± 5	—	mV	
Load Regulation	ΔReg_{load}	Over I_o range	—	± 5	—	mV	
Total Output Variation	ΔReg_{tot}	Includes set-point, line, load, $-40^\circ\text{C} \leq T_a \leq +85^\circ\text{C}$	—	—	± 3	⁽²⁾ % V_o	
Output Voltage Adjust Range	ΔV_{adj}	Over V_{in} range	1.2	—	5.5	V	
Efficiency	η	$I_o = 5\text{ A}$ $R_{SET} = 280\ \Omega$ $V_o = 5.0\text{ V}$ $R_{SET} = 2.0\ \text{k}\Omega$ $V_o = 3.3\text{ V}$ $R_{SET} = 4.32\ \text{k}\Omega$ $V_o = 2.5\text{ V}$ $R_{SET} = 8.06\ \text{k}\Omega$ $V_o = 2.0\text{ V}$ $R_{SET} = 11.5\ \text{k}\Omega$ $V_o = 1.8\text{ V}$ $R_{SET} = 24.3\ \text{k}\Omega$ $V_o = 1.5\text{ V}$ $R_{SET} = \text{open cct}$ $V_o = 1.2\text{ V}$	— — — — — — —	93 91 89 88 87 86 84	— — — — — — —	— — — — — — —	%
V_o Ripple (pk-pk)	V_r	20 MHz bandwidth	$V_o \leq 2.5\text{ V}$	—	25	—	mVpp
			$V_o > 2.5\text{ V}$	—	1	—	% V_o
Over-Current Threshold	I_o trip	Reset, followed by auto-recovery	—	14	—	A	
Transient Response	t_{tr} ΔV_{tr}	1 A/ μs load step, 50 to 100 % $I_{o,max}$, $C_3 = 100\ \mu\text{F}$ Recovery Time V_o over/undershoot	—	70	—	μSec	
			—	100	—	mV	
Track Input Current (pin 2)	$I_{in, track}$	Pin to GND	—	—	-0.13	⁽³⁾ mA	
Track Slew Rate Capability	dV_{track}/dt	$C_{out} \leq C_{out(max)}$	—	—	1	V/ms	
Under-Voltage Lockout	UVLO	V_{in} increasing V_{in} decreasing	— 8.8	9.5 9	10.4 —	V	
Inhibit Control (pin 4) Input High Voltage Input Low Voltage	V_{IH} V_{IL}	Referenced to GND	$V_{in} - 0.5$	—	Open	⁽³⁾ V	
			-0.2	—	0.5		
Input Low Current	$I_{in, inhibit}$	Pin to GND	—	-0.24	—	mA	
Input Standby Current	$I_{in, inh}$	Inhibit (pin 4) to GND, Track (pin 2) open	—	10	—	mA	
Switching Frequency	f_s	Over V_{in} and I_o ranges	260	320	380	kHz	
External Input Capacitance	C_1		100 ⁽⁴⁾	—	—	μF	
External Output Capacitance	C_3	Capacitance value	0 0	100 ⁽⁵⁾ —	3,300 300	⁽⁶⁾ μF	
		Equiv. series resistance (non-ceramic)	4 ⁽⁷⁾	—	—		
Reliability	MTBF	Per Bellcore TR-332 50 % stress, $T_a = 40^\circ\text{C}$, ground benign	5.9	—	—	10 ⁶ Hrs	

- Notes:**
- See SOA curves or consult factory for appropriate derating.
 - The set-point voltage tolerance is affected by the tolerance and stability of R_{SET} . The stated limit is unconditionally met if R_{SET} has a tolerance of 1 % with 100 ppm/°C or better temperature stability.
 - This control pin has an internal pull-up to the input voltage V_{in} (7.5 V for pin 2). If it is left open-circuit the module will operate when input power is applied. A small low-leakage (<100 nA) MOSFET is recommended for control. For further information, consult the related application note.
 - A 100 μF electrolytic input capacitor is required for proper operation. The electrolytic capacitor must be rated for a minimum of 750 mA rms of ripple current. An additional 10 μF ceramic capacitor is required for output voltages 3.3 V and higher. For further information, consult the related application note on capacitor selection.
 - An external output capacitor is not required for basic operation. Adding 100 μF of distributed capacitance at the load will improve the transient response.
 - This is the calculated maximum. The minimum ESR limitation will often result in a lower value. Consult the application notes for further guidance.
 - This is the typical ESR for all the electrolytic (non-ceramic) output capacitance. Use 7 m Ω as the minimum when using max-ESR values to calculate.

PTH12050W Characteristic Data; $V_{in} = 12\text{ V}$ (See Note A)

PTH12050W Safe Operating Area; $V_{in} = 12\text{ V}$ (See Note B)

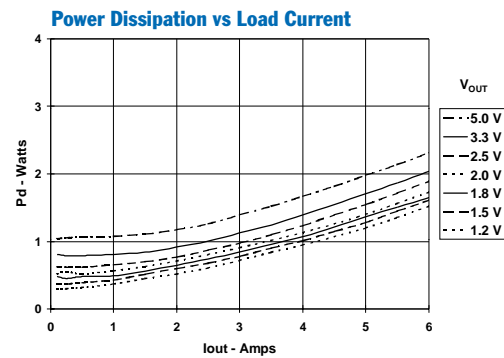
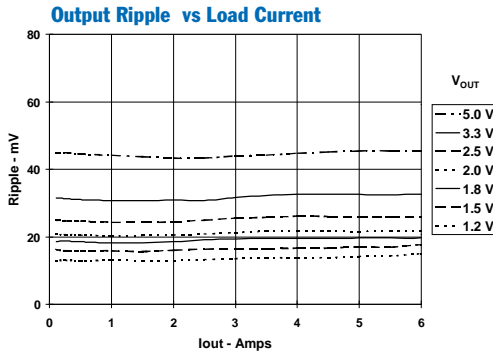
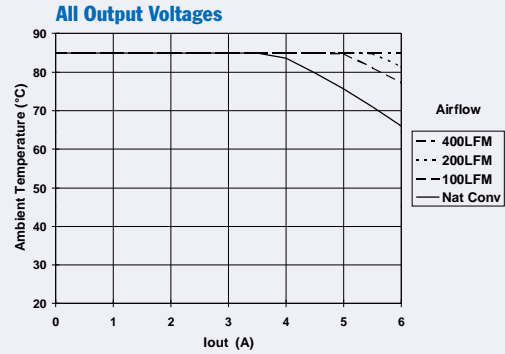
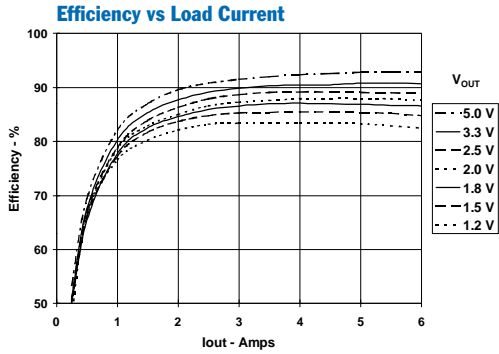

Note A: Characteristic data has been developed from actual products tested at 25°C. This data is considered typical data for the Converter.

Note B: SOA curves represent the conditions at which internal components are at or below the manufacturer's maximum operating temperatures. Derating limits apply to modules soldered directly to a 4 in. × 4 in. double-sided PCB with 1 oz. copper.

Specifications (Unless otherwise stated, $T_a = 25^\circ\text{C}$, $V_{in} = 12\text{ V}$, $V_{out} = 1.8\text{ V}$, $C_1 = 100\ \mu\text{F}$, $C_2 = 10\ \mu\text{F}$, $C_3 = 0\ \mu\text{F}$, and $I_o = I_{o,max}$)

Characteristics	Symbols	Conditions	PTH12050L			Units
			Min	Typ	Max	
Output Current	I_o	Over ΔV_{adj} range 85 °C, 400 LFM airflow 60 °C, natural convection	0 0	— —	6 6	⁽¹⁾ ⁽¹⁾ A
Input Voltage Range	V_{in}	Over I_o range	10.8	—	13.2	V
Set-Point Voltage Tolerance	$V_o\text{tol}$		—	—	± 2	⁽²⁾ % V_o
Temperature Variation	ΔReg_{temp}	$-40^\circ\text{C} < T_a < +85^\circ\text{C}$	—	± 0.5	—	% V_o
Line Regulation	ΔReg_{line}	Over V_{in} range	—	± 5	—	mV
Load Regulation	ΔReg_{load}	Over I_o range	—	± 5	—	mV
Total Output Variation	ΔReg_{tot}	Includes set-point, line, load, $-40^\circ\text{C} \leq T_a \leq +85^\circ\text{C}$	—	—	± 3	⁽²⁾ % V_o
Output Voltage Adjust Range	ΔV_{adj}	Over V_{in} range	0.8	—	1.8	V
Efficiency	η	$I_o = 5\text{ A}$ $R_{SET} = 130\ \Omega$ $V_o = 1.8\text{ V}$ $R_{SET} = 3.57\text{ k}\Omega$ $V_o = 1.5\text{ V}$ $R_{SET} = 12.1\text{ k}\Omega$ $V_o = 1.2\text{ V}$ $R_{SET} = 32.4\text{ k}\Omega$ $V_o = 1.0\text{ V}$ $R_{SET} = \text{open cct}$ $V_o = 0.8\text{ V}$	— — — — —	88 87 85 83 81	— — — — —	%
V_o Ripple (pk-pk)	V_r	20 MHz bandwidth $V_o > 1.0\text{ V}$ $V_o \leq 1.0\text{ V}$	— —	30 20	— —	mVpp
Over-Current Threshold	$I_o\text{ trip}$	Reset, followed by auto-recovery	—	14	—	A
Transient Response	t_{tr} ΔV_{tr}	1 A/ μs load step, 50 to 100 % I_o,max , $C_3 = 100\ \mu\text{F}$ Recovery Time V_o over/undershoot	— —	70 100	— —	μSec mV
Track Input Current (pin 2)	$I_{in, track}$	Pin to GND	—	—	-0.13	⁽³⁾ mA
Track Slew Rate Capability	dV_{track}/dt	$C_{out} \leq C_{out(max)}$	—	—	1	V/ms
Under-Voltage Lockout	UVLO	V_{in} increasing V_{in} decreasing	— 8.8	9.5 9	10.4 —	V
Inhibit Control (pin 4) Input High Voltage Input Low Voltage Input Low Current	V_{IH} V_{IL} $I_{in, inhibit}$	Referenced to GND Pin to GND	$V_{in} - 0.5$ -0.2	— —	Open 0.5	⁽³⁾ V mA
Input Standby Current	$I_{in, inh}$	Inhibit (pin 4) to GND, Track (pin 2) open	—	10	—	mA
Switching Frequency	f_s	Over V_{in} and I_o ranges	200	250	300	kHz
External Input Capacitance	C_1		100 ⁽⁴⁾	—	—	μF
External Output Capacitance	C_3	Capacitance value non-ceramic ceramic	0 0	100 ⁽⁵⁾ —	3,300 300	⁽⁶⁾ μF
		Equiv. series resistance (non-ceramic)	4 ⁽⁷⁾	—	—	
Reliability	MTBF	Per Bellcore TR-332 50 % stress, $T_a = 40^\circ\text{C}$, ground benign	5.9	—	—	10 ⁶ Hrs

- Notes:** (1) See SOA curves or consult factory for appropriate derating.
 (2) The set-point voltage tolerance is affected by the tolerance and stability of R_{SET} . The stated limit is unconditionally met if R_{SET} has a tolerance of 1 % with 100 ppm/°C or better temperature stability.
 (3) This control pin has an internal pull-up to the input voltage V_{in} (7.5 V for pin 2). If it is left open-circuit the module will operate when input power is applied. A small low-leakage (<100 nA) MOSFET is recommended for control. For further information, consult the related application note.
 (4) A 100 μF electrolytic input capacitor is required for proper operation. The electrolytic capacitor must be rated for a minimum of 750 mA rms of ripple current. An additional 10 μF ceramic capacitor is required for output voltages 3.3 V and higher. For further information, consult the related application note on capacitor selection.
 (5) An external output capacitor is not required for basic operation. Adding 100 μF of distributed capacitance at the load will improve the transient response.
 (6) This is the calculated maximum. The minimum ESR limitation will often result in a lower value. Consult the application notes for further guidance.
 (7) This is the typical ESR for all the electrolytic (non-ceramic) output capacitance. Use 7 m Ω as the minimum when using max-ESR values to calculate.

PTH12050L Characteristic Data; $V_{in} = 12\text{ V}$ (See Note A)

PTH12050L Safe Operating Area; $V_{in} = 12\text{ V}$ (See Note B)

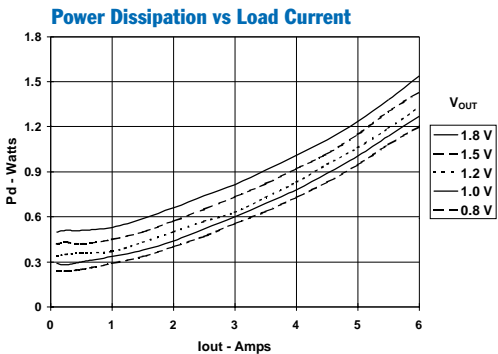
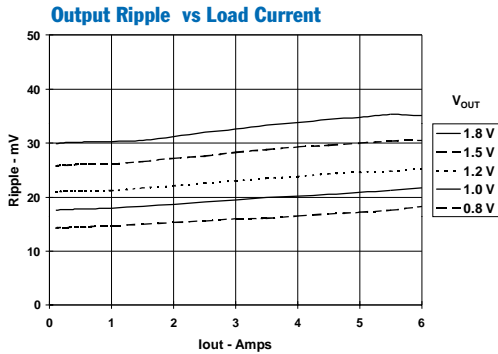
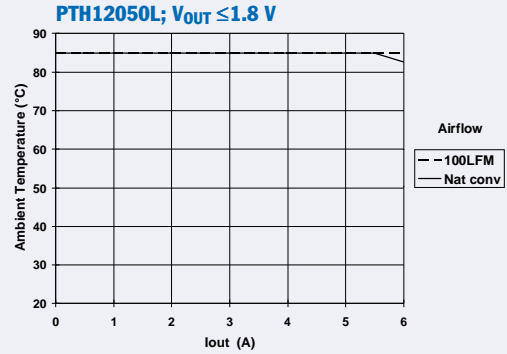
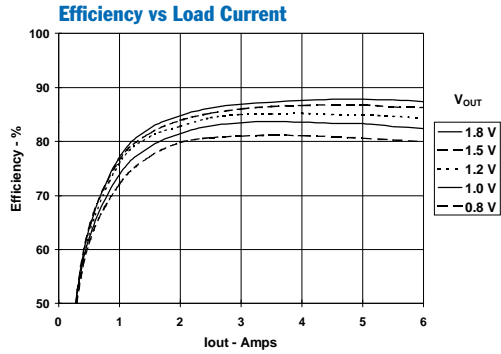

Note A: Characteristic data has been developed from actual products tested at 25°C. This data is considered typical data for the Converter.

Note B: SOA curves represent the conditions at which internal components are at or below the manufacturer's maximum operating temperatures. Derating limits apply to modules soldered directly to a 4 in. × 4 in. double-sided PCB with 1 oz. copper.

Capacitor Recommendations for the PTH12050 Series of Power Modules

Input Capacitor

The recommended input capacitor(s) is determined by the 100 μF minimum capacitance and 750 mArms minimum ripple current rating. A 10- μF X5R/X7R ceramic capacitor may also be added to reduce the reflected input ripple current. This is recommended for output voltage set points of 3.3 V and higher.

Ripple current, less than 100 m Ω equivalent series resistance (ESR) and temperature are major considerations when selecting input capacitors. Unlike polymer-tantalum capacitors, regular tantalum capacitors have a recommended minimum voltage rating of $2 \times$ (max. DC voltage + AC ripple). This is standard practice to ensure reliability. Only a few tantalum capacitors have sufficient voltage rating to meet this requirement. At temperatures below 0 $^{\circ}\text{C}$, the ESR of aluminum electrolytic capacitors increases. For these applications Os-Con, polymer-tantalum, and polymer-aluminum types should be considered.

Output Capacitors (Optional)

For applications with load transients (sudden changes in load current), regulator response will benefit from external output capacitance. The value of 330 μF is used to define the transient response specification (see data sheet). For most applications, a high quality computer-grade aluminum electrolytic capacitor is adequate. These capacitors provide decoupling over the frequency range, 2 kHz to 150 kHz, and are suitable for ambient temperatures above 0 $^{\circ}\text{C}$. Below 0 $^{\circ}\text{C}$, tantalum, ceramic or Os-Con type capacitors are recommended. When using one or more non-ceramic capacitors, the calculated equivalent ESR should be no lower than 4 m Ω (7 m Ω using the manufacturer's maximum ESR for a single capacitor). A list of preferred low-ESR type capacitors are identified in Table 2-1.

In addition to electrolytic capacitance, adding a 10- μF X5R/X7R ceramic capacitor to the output will reduce the output ripple voltage and improve the regulator's transient response. The measurement of both the output ripple and transient response is also best achieved across a 10- μF ceramic capacitor.

Ceramic Capacitors

Above 150 kHz the performance of aluminum electrolytic capacitors is less effective. Multilayer ceramic capacitors have very low ESR and a resonant frequency higher than the bandwidth of the regulator. They can be used to reduce the reflected ripple current at the input as well as improve the transient response of the output. When used on the output their combined ESR is not critical as long as the total value of ceramic capacitance does not exceed 300 μF . Also, to prevent the formation of local resonances, do not place more than five identical ceramic capacitors in parallel with values of 10 μF or greater.

Tantalum Capacitors

Tantalum type capacitors are most suited for use on the output bus, and are recommended for applications where the ambient operating temperature can be less than 0 $^{\circ}\text{C}$. The AVX TPS, Sprague 593D/594/595 and Kemet T495/T510 capacitor series are suggested over other tantalum types due to their higher rated surge, power dissipation, and ripple current capability. As a caution many general purpose tantalum capacitors have considerably higher ESR, reduced power dissipation and lower ripple current capability. These capacitors are also less reliable as they have no surge current rating. Tantalum capacitors that do not have a stated ESR or surge current rating are not recommended for power applications.

When specifying Os-con and polymer tantalum capacitors for the output, the minimum ESR limit will be encountered well before the maximum capacitance value is reached.

Capacitor Table

Table 1-1 identifies the characteristics of capacitors from a number of vendors with acceptable ESR and ripple current (rms) ratings. The recommended number of capacitors required at both the input and output buses is identified for each capacitor type.

This is not an extensive capacitor list. Capacitors from other vendors are available with comparable specifications. Those listed are for guidance. The RMS ripple current rating and ESR (at 100 kHz) are critical parameters necessary to insure both optimum regulator performance and long capacitor life.

Designing for Very Fast Load Transients

The transient response of the DC/DC converter has been characterized using a load transient with a di/dt of 1 A/ μs . The typical voltage deviation for this load transient is given in the data sheet specification table using the optional value of output capacitance. As the di/dt of a transient is increased, the response of a converter's regulation circuit ultimately depends on its output capacitor decoupling network. This is an inherent limitation with any DC/DC converter once the speed of the transient exceeds its bandwidth capability. If the target application specifies a higher di/dt or lower voltage deviation, the requirement can only be met with additional output capacitor decoupling. In these cases special attention must be paid to the type, value and ESR of the capacitors selected.

If the transient performance requirements exceed that specified in the data sheet, or the total amount of load capacitance is above 3,000 μF , the selection of output capacitors becomes more important. For further guidance consult the separate application note, "Selecting Output Capacitors for PTH Products in High-Performance Applications."

Table 2-1: Input/Output Capacitors

Capacitor Vendor/ Type Series (Style)	Capacitor Characteristics					Quantity		Vendor Number
	Working Voltage	Value (µF)	Max. ESR @ 100 kHz	Max. Ripple at 85 °C Current (Irms)	Physical Size (mm)	Input Bus	Output Bus	
Panasonic, Aluminum FC (Radial) FK (SMD)	25 V 35 V 25 V	330 µF 180 µF 470 µF	0.090 Ω 0.090 Ω 0.080 Ω	755 mA 755 mA 850 mA	10×12.5 10×12.5 10×10.2	1 1 1	1 1 1	EEUFC1E331 EEUFC1V181 EEVFK1E471P
United Chemi-con PXA-Poly-Aluminum (SMD) FP, Os-con (Radial) FS, Os-con (Radial) LXZ, Aluminum (Radial)	16 V 20 V 20 V 35 V	150 µF 120 µF 100 µF 220 µF	0.026 Ω 0.024 Ω 0.030 Ω 0.090 Ω	3430 mA 3100 mA 2740 mA 760 mA	10×7.7 8×10.5 8×10.5 10×12.5	1 1 1 1	≤4 ≤4 ≤4 1	PXA16VC151MJ80TP 20FP120MG 20FS100M LXZ35VB221M10X12LL
Nichicon Aluminum HD, (Radial) PM, (Radial)	25 V 35 V	220 µF 220 µF	0.072 Ω 0.090 Ω	760 mA 770 mA	8×11.5 10×15	1 1	1 1	UHD1E221MPR UPM1V221MHH6
Panasonic, Poly-Aluminum: WA (SMD) S/SE (SMD)	16 V 6.3 V [1]	100 µF 180 µF	0.039 Ω 0.005 Ω	2500 mA 4000 mA	8×6.9 7.3×4.3×4.2	1 N/R [2]	≤5 ≤1	EEFWA1C101P EEFSE0J181R (V _o ≤5.1V)
Sanyo SVP, Os-con (SMD) SP, Os-con (Radial) TPE, Pos-Ccap (SMD)	20 V 20 V 10 V	100 µF 120 µF 220 µF	0.024 Ω 0.024 Ω 0.025 Ω	>3300 mA >3100 mA >2400 mA	8×12 8×10.5 7.3×5.7	1 1 1	≤4 ≤4 ≤4	20SVP100M 20SP120M 10TPE220ML
AVX, Tantalum TPS (SMD)	10 V 10 V 25 V	100 µF 220 µF 68 µF	0.100 Ω 0.100 Ω 0.095 Ω	>1090 mA >1414 mA >1451 mA	7.3L ×4.3W ×4.1H	N/R [2] N/R [2] 2	≤5 ≤5 ≤5	TPSD107M010R0100 TPSV227M010R0100 TPSV686M025R0095
Kemet T520, Poy-Tant (SMD) T495, Tantalum (SMD)	10 V 10 V	100 µF 100 µF	0.080 Ω 0.100 Ω	1200 mA >1100 mA	7.3L×5.7W ×4.0H	N/R [2] N/R [2]	≤5 ≤5	T520D107M010AS T495X107M010AS
Vishay-Sprague 594D, Tantalum (SMD) 94SP, Organic (Radial)	10 V 25 V 16 V	150 µF 68 µF 100 µF	0.090 Ω 0.095 Ω 0.070 Ω	1100 mA 1600 mA 2890 mA	7.3L×6.0W ×4.1H 10×10.5	N/R [2] 2 1	≤5 ≤5 ≤5	594D157X0010C2T 594D686X0025R2T 94SP107X0016FBP
Kemet, Ceramic X5R (SMD)	16 V 6.3 V	10 µF 47 µF	0.002 Ω 0.002 Ω	—	1210 case 3225 mm	1 [3] N/R [2]	≤5 ≤5	C1210C106M4PAC C1210C476K9PAC
Murata, Ceramic X5R (SMD)	6.3 V 6.3 V 16 V 16 V	100 µF 47 µF 22 µF 10 µF	0.002 Ω	—	1210 case 3225 mm	N/R [2] N/R [2] 1 [3] 1 [3]	≤3 ≤5 ≤5 ≤5	GRM32ER60J107M GRM32ER60J476M GRM32ER61C226K GRM32DR61C106K
TDK, Ceramic X5R (SMD)	6.3 V 6.3 V 16 V 16 V	100 µF 47 µF 22 µF 10 µF	0.002 Ω	—	1210 case 3225 mm	N/R [2] N/R [2] 1 [3] 1 [3]	≤3 ≤5 ≤5 ≤5	C3225X5R0J107MT C3225X5R0J476MT C3225X5R1C226MT C3225X5R1C106MT

[1] The voltage rating of this capacitor only allows it to be used for output voltages that are equal to or less than 5.1 V.

[2] N/R –Not recommended. The capacitor voltage rating does not meet the minimum derated operating limits.

[3] Ceramic capacitors may be used to complement electrolytic types at the input to further reduce high-frequency ripple current.

Adjusting the Output Voltage of the PTH12050x Wide-Output Adjust Power Modules

The V_o Adjust control (pin 5) sets the output voltage of the PTH12050 product. The adjustment range is from 1.2 V to 5.5 V for the W-suffix module, and 0.8 V to 1.8 V for L-suffix module. The adjustment method requires the addition of a single external resistor, R_{set} , that must be connected directly between the V_o Adjust and GND pins¹. Table 2-1 gives the preferred value of the external resistor for a number of standard voltages, along with the actual output voltage that this resistance value provides. Figure 2-1 shows the placement of the required resistor.

Table 2-1; Preferred Values of R_{set} for Standard Output Voltages

V_{out} (Req'd)	PTH12050W		PTH12050L	
	R_{set}	V_{out} (Actual)	R_{set}	V_{out} (Actual)
5 V	280 Ω	5.009 V	N/A	N/A
3.3 V	2.0 k Ω	3.294 V	N/A	N/A
2.5 V	4.32 k Ω	2.503 V	N/A	N/A
2 V	8.06 k Ω	2.010 V	N/A	N/A
1.8 V	11.5 k Ω	1.801 V	130 Ω	1.800 V
1.5 V	24.3 k Ω	1.506 V	3.57 k Ω	1.499 V
1.2 V	Open	1.200 V	12.1 k Ω	1.201 V
1.1 V	N/A	N/A	18.7 k Ω	1.101 V
1.0 V	N/A	N/A	32.4 k Ω	0.999 V
0.9 V	N/A	N/A	71.5 k Ω	0.901 V
0.8 V	N/A	N/A	Open	0.800 V

For other output voltages the value of the required resistor can either be calculated, or simply selected from the range of values given in Table 2-3. The following formula may be used for calculating the adjust resistor value. Select the appropriate value for the parameters, R_s and V_{min} , from Table 2.2.

$$R_{set} = 10 \text{ k}\Omega \cdot \frac{0.8 \text{ V}}{V_{out} - V_{min}} - R_s \text{ k}\Omega$$

Table 2.2; Adjust Formula Parameters

Pt. No.	PTH12050W	PTH12050L
V_{min}	1.2 V	0.8 V
V_{max}	5.5 V	1.8 V
R_s	1.82 k Ω	7.87 k Ω

Figure 2-1; V_o Adjust Resistor Placement

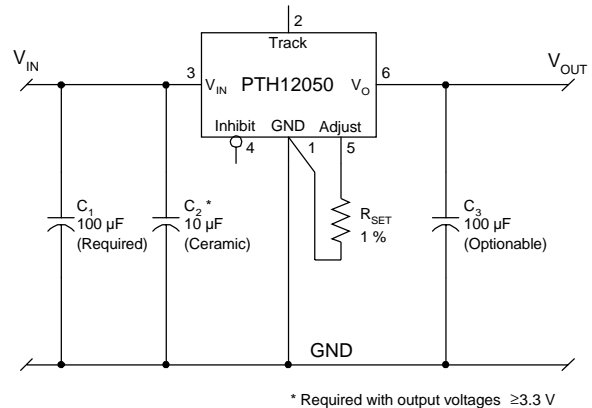

Notes:

1. A 0.05-W rated resistor can be used. The tolerance should be 1 %, with a temperature stability of 100 ppm/ $^{\circ}$ C or better. Place the resistor as close to the regulator as possible. Connect the resistor directly between pins 5 and 1 using dedicated PCB traces.
2. Never connect capacitors from V_o Adjust to either GND or V_{out} . Any capacitance added to the V_o Adjust pin will affect the stability of the regulator.

Table 2-3; Output Voltage Set-Point Resistor Values

PTH12050W				PTH12050L	
V _{OUT}	R _{SET}	V _{OUT}	R _{SET}	V _{OUT}	R _{SET}
1.200	Open	2.70	3.51 k Ω	0.800	Open
1.225	318.0 k Ω	2.75	3.34 k Ω	0.825	312.0 k Ω
1.250	158.0 k Ω	2.80	3.18 k Ω	0.850	152.0 k Ω
1.275	105.0 k Ω	2.85	3.03 k Ω	0.875	98.8 k Ω
1.300	78.2 k Ω	2.90	2.89 k Ω	0.900	72.1 k Ω
1.325	62.2 k Ω	2.95	2.75 k Ω	0.925	56.1 k Ω
1.350	51.5 k Ω	3.00	2.62 k Ω	0.950	45.5 k Ω
1.375	43.9 k Ω	3.05	2.50 k Ω	0.975	37.8 k Ω
1.400	38.2 k Ω	3.10	2.39 k Ω	1.000	32.1 k Ω
1.425	33.7 k Ω	3.15	2.28 k Ω	1.025	27.7 k Ω
1.450	30.2 k Ω	3.20	2.18 k Ω	1.050	24.1 k Ω
1.475	27.3 k Ω	3.25	2.08 k Ω	1.075	21.2 k Ω
1.50	24.8 k Ω	3.30	1.99 k Ω	1.100	18.8 k Ω
1.55	21.0 k Ω	3.35	1.90 k Ω	1.125	16.7 k Ω
1.60	18.2 k Ω	3.40	1.82 k Ω	1.150	15.0 k Ω
1.65	16.0 k Ω	3.50	1.66 k Ω	1.175	13.5 k Ω
1.70	14.2 k Ω	3.60	1.51 k Ω	1.200	12.1 k Ω
1.75	12.7 k Ω	3.70	1.38 k Ω	1.225	11.0 k Ω
1.80	11.5 k Ω	3.80	1.26 k Ω	1.250	9.91 k Ω
1.85	10.5 k Ω	3.90	1.14 k Ω	1.275	8.97 k Ω
1.90	9.61 k Ω	4.00	1.04 k Ω	1.300	8.13 k Ω
1.95	8.85 k Ω	4.10	939 Ω	1.325	7.37 k Ω
2.00	8.18 k Ω	4.20	847 Ω	1.350	6.68 k Ω
2.05	7.59 k Ω	4.30	761 Ω	1.375	6.04 k Ω
2.10	7.07 k Ω	4.40	680 Ω	1.400	5.46 k Ω
2.15	6.60 k Ω	4.50	604 Ω	1.425	4.93 k Ω
2.20	6.18 k Ω	4.60	533 Ω	1.450	4.44 k Ω
2.25	5.80 k Ω	4.70	466 Ω	1.475	3.98 k Ω
2.30	5.45 k Ω	4.80	402 Ω	1.50	3.56 k Ω
2.35	5.14 k Ω	4.90	342 Ω	1.55	2.8 k Ω
2.40	4.85 k Ω	5.00	285 Ω	1.60	2.13 k Ω
2.45	4.58 k Ω	5.10	231 Ω	1.65	1.54 k Ω
2.50	4.33 k Ω	5.20	180 Ω	1.70	1.02 k Ω
2.55	4.11 k Ω	5.30	131 Ω	1.75	551 Ω
2.60	3.89 k Ω	5.40	85 Ω	1.80	130 Ω
2.65	3.70 k Ω	5.50	41 Ω		

Features of the PTH Family of Non-Isolated Wide Output Adjust Power Modules

Point-of-Load Alliance

The PTH family of non-isolated, wide-output adjust power modules from Texas Instruments are optimized for applications that require a flexible, high performance module that is small in size. These products are part of the “Point-of-Load Alliance” (POLA), which ensures compatible footprint, interoperability and true second sourcing for customer design flexibility. The POLA is a collaboration between Texas Instruments, Artesyn Technologies, and Astec Power to offer customers advanced non-isolated modules that provide the same functionality and form factor. Product series covered by the alliance includes the PTHxx050W (6 A), PTHxx060W (10 A), PTHxx010W (15/12 A), PTHxx020W (22/18 A), and the PTHxx030W (30/26 A).

From the basic, “Just Plug it In” functionality of the 6-A modules, to the 30-A rated feature-rich PTHxx030W, these products were designed to be very flexible, yet simple to use. The features vary with each product. Table 3-1 provides a quick reference to the available features by product and input bus voltage.

Table 3-1; Operating Features by Series and Input Bus Voltage

Series	Input Bus	I _{OUT}	Adjust (Trim)	On/Off Inhibit	Over-Current	Pre-Bias Startup	Auto-Track™	Margin Up/Down	Output Sense	Thermal Shutdown
PTHxx050	3.3 V / 5 V	6 A	•	•	•	•	•			
	12 V	6 A	•	•	•	•	•			
PTHxx060	3.3 V / 5 V	10 A	•	•	•	•	•	•	•	
	12 V	8 A	•	•	•	•	•	•	•	
PTHxx010	3.3 V / 5 V	15 A	•	•	•	•	•	•	•	•
	12 V	12 A	•	•	•	•	•	•	•	•
PTHxx020	3.3 V / 5 V	22 A	•	•	•	•	•	•	•	•
	12 V	18 A	•	•	•	•	•	•	•	•
PTHxx030	3.3 V / 5 V	30 A	•	•	•	•	•	•	•	•
	12 V	26 A	•	•	•	•	•	•	•	•

For simple point-of-use applications, the PTH12050W (6 A) provides operating features such as an on/off inhibit, output voltage trim, and over-current protection. The PTH12060W (10 A), and PTH12010W (12 A) include an output voltage sense, and margin up/down controls. Then the higher output current, PTH12020W (18 A) and

PTH12030W (26 A) products incorporate over-temperature shutdown protection. All of the products referenced in Table 3-1 include Auto-Track™. This is a feature unique to the PTH family, and was specifically designed to simplify the task of sequencing the supply voltage in a power system. These and other features are described in the following sections.

Soft-Start Power Up

The Auto-Track feature allows the power-up of multiple PTH modules to be directly controlled from the *Track* pin. However in a stand-alone configuration, or when the Auto-Track feature is not being used, the *Track* pin should be directly connected to the input voltage, V_{in} (see Figure 3-1).

Figure 3-1

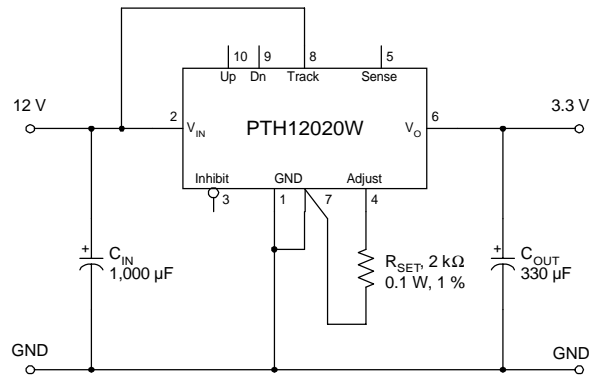

When the *Track* pin is connected to the input voltage the Auto-Track function is permanently disengaged. This allows the module to power up entirely under the control of its internal soft-start circuitry. When power up is under soft-start control, the output voltage rises to the set-point at a quicker and more linear rate.

Figure 3-2

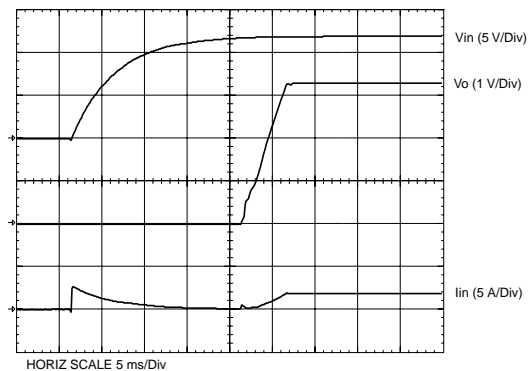

From the moment a valid input voltage is applied, the soft-start control introduces a short time delay (typically 5 ms-10 ms) before allowing the output voltage to rise. The output then progressively rises to the module's set-point voltage. Figure 3-2 shows the soft-start power-up characteristic of the 18-A output product (PTH12020W), operating from a 12-V input bus and configured for a 3.3-V output. The waveforms were measured with a 5-A resistive load and the Auto-Track feature disabled. The initial rise in input current when the input voltage first starts to rise is the charge current drawn by the input capacitors. Power-up is complete within 15 ms.

Over-Current Protection

For protection against load faults, all modules incorporate output over-current protection. Applying a load that exceeds the regulator's over-current threshold will cause the regulated output to shut down. Following shutdown a module will periodically attempt to recover by initiating a soft-start power-up. This is described as a "hiccup" mode of operation, whereby the module continues in a cycle of successive shutdown and power up until the load fault is removed. During this period, the average current flowing into the fault is significantly reduced. Once the fault is removed, the module automatically recovers and returns to normal operation.

Over-Temperature Protection (OTP)

The PTH12020W and PTH12030W of products have over-temperature protection. These products have an on-board temperature sensor that protects the module's internal circuitry against excessively high temperatures. A rise in the internal temperature may be the result of a drop in airflow, or a high ambient temperature. If the internal temperature exceeds the OTP threshold, the module's *Inhibit* control is automatically pulled low. This turns the output off. The output voltage will drop as the external output capacitors are discharged by the load circuit. The recovery is automatic, and begins with a soft-start power up. It occurs when the the sensed temperature decreases by about 10 °C below the trip point.

Note: The over-temperature protection is a last resort mechanism to prevent thermal stress to the regulator. Operation at or close to the thermal shutdown temperature is not recommended and will reduce the long-term reliability of the module. Always operate the regulator within the specified Safe Operating Area (SOA) limits for the worst-case conditions of ambient temperature and airflow.

Output On/Off Inhibit

For applications requiring output voltage on/off control, each series of the PTH family incorporates an output *Inhibit* control pin. The inhibit feature can be used wherever there is a requirement for the output voltage from

the regulator to be turned off.

The power modules function normally when the *Inhibit* pin is left open-circuit, providing a regulated output whenever a valid source voltage is connected to V_{in} with respect to GND .

Figure 3-3 shows the typical application of the inhibit function. Note the discrete transistor (Q_1). The *Inhibit* input has its own internal pull-up to V_{in} potential (12 V). The input is not compatible with TTL logic devices. An open-collector (or open-drain) discrete transistor is recommended for control.

Figure 3-3

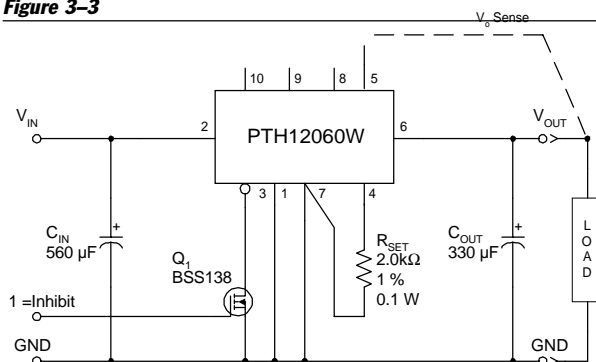

Turning Q_1 on applies a low voltage to the *Inhibit* control pin and disables the output of the module. If Q_1 is then turned off, the module will execute a soft-start power-up sequence. A regulated output voltage is produced within 20 msec. Figure 3-4 shows the typical rise in both the output voltage and input current, following the turn-off of Q_1 . The turn off of Q_1 corresponds to the rise in the waveform, $Q_1 V_{ds}$. The waveforms were measured with a 5-A constant current load.

Figure 3-4

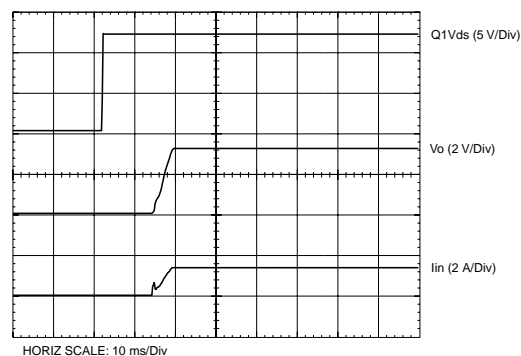

Auto-Track™ Function

The Auto-Track function is unique to the PTH family, and is available with the all “Point-of-Load Alliance” (POLA) products. Auto-Track was designed to simplify the amount of circuitry required to make the output voltage from each module power up and power down in sequence. The sequencing of two or more supply voltages during power up is a common requirement for complex mixed-signal applications, that use dual-voltage VLSI ICs such as DSPs, micro-processors, and ASICs.

How Auto-Track Works

Auto-Track works by forcing the module's output voltage to follow a voltage presented at the *Track* control pin. This control range is limited to between 0 V and the module's set-point voltage. Once the track-pin voltage is raised above the set-point voltage, the module's output remains at its set-point¹. As an example, if the Track pin of a 2.5-V regulator is at 1 V, the regulated output will be 1 V. But if the voltage at the Track pin rises to 3 V, the regulated output will not go higher than 2.5 V.

When under track control, the regulated output from the module follows the voltage at its Track pin on a volt-for-volt basis. By connecting the Track pin of a number of these modules together, the output voltages will follow a common signal during power-up and power-down. The control signal can be an externally generated master ramp waveform, or the output voltage from another power supply circuit³. For convenience the Track control incorporates an internal RC charge circuit. This operates off the module's input voltage to produce a suitable rising waveform at power up.

Typical Application

The basic implementation of Auto-Track allows for simultaneous voltage sequencing of a number of Auto-Track compliant modules. Connecting the Track control pins of two or more modules forces the Track control of all modules to follow the same collective RC ramp waveform, and allows them to be controlled through a single transistor or switch; Q₁ in Figure 3-5.

To initiate a power-up sequence, it is recommended that the Track control be first pulled to ground potential. This should be done at or before input power is applied to the modules, and then held for at least 10 ms thereafter. This brief period gives the modules time to complete their internal soft-start initialization. Applying a logic-level high signal to the circuit's On/Off Control turns Q₁ on and applies a ground signal to the Track pins. After completing their internal soft-start initialization, the output of all modules will remain at zero volts while Q₁ is on.

10 ms after a valid input voltage has been applied to the modules, Q₁ may be turned off. This allows the track control voltage to automatically rise toward to the modules' input voltage. During this period the output voltage of each module will rise in unison with other modules, to its respective set-point voltage.

Figure 3-6 shows the output voltage waveforms from the circuit of Figure 3-5 after the On/Off Control is set from a high to a low-level voltage. The waveforms, Vo₁ and Vo₂ represent the output voltages from the two power modules, U₁ (3.3 V) and U₂ (2 V) respectively. Vo₁ and Vo₂ are shown rising together to produce the desired simultaneous power-up characteristic.

The same circuit also provides a power-down sequence. Power down is the reverse of power up, and is accomplished by lowering the track control voltage back to zero volts. The important constraint is that a valid input voltage must be maintained until the power down is complete. It also requires that Q₁ be turned off relatively slowly. This is so that the Track control voltage does not fall faster than Auto-Track's slew rate capability, which is 1 V/ms. The components R₁ and C₁ in Figure 3-5 limit the rate at which Q₁ can pull down the Track control voltage. The values of 100 k-ohm and 0.1 μF correlate to a decay rate of about 0.17 V/ms.

The power-down sequence is initiated with a low-to-high transition at the On/Off Control input to the circuit. Figure 3-7 shows the power-down waveforms. As the Track control voltage falls below the nominal set-point voltage of each power module, then its output voltage decays with all the other modules under Auto-Track control.

Notes on Use of Auto-Track™

1. The Track pin voltage must be allowed to rise above the module's set-point voltage before the module can regulate at its adjusted set-point voltage.
2. The Auto-Track function will track almost any voltage ramp during power up, and is compatible with ramp speeds of up to 1 V/ms.
3. The absolute maximum voltage that may be applied to the Track pin is the input voltage V_{in}.
4. The module will not follow a voltage at its Track control input until it has completed its soft-start initialization. This takes about 10 ms from the time that the module has sensed that a valid voltage has been applied its input. During this period, it is recommended that the Track pin be held at ground potential.
5. The module is capable of both sinking and sourcing current when following a voltage at its Track pin. Therefore startup into an output prebias cannot be supported when a module is under Auto-Track control. *Note: A pre-bias holdoff is not necessary when all supply voltages rise simultaneously under the control of Auto-Track.*
6. The Auto-Track function can be disabled by connecting the Track pin to the input voltage (V_{in}). When Auto-Track is disabled, the output voltage will rise at a quicker and more linear rate after input power is applied.

Application Notes

PTH Series of Wide-Output Adjust Power Modules (12-V Input)

Figure 3-5; Sequenced Power Up & Power Down Using Auto-Track

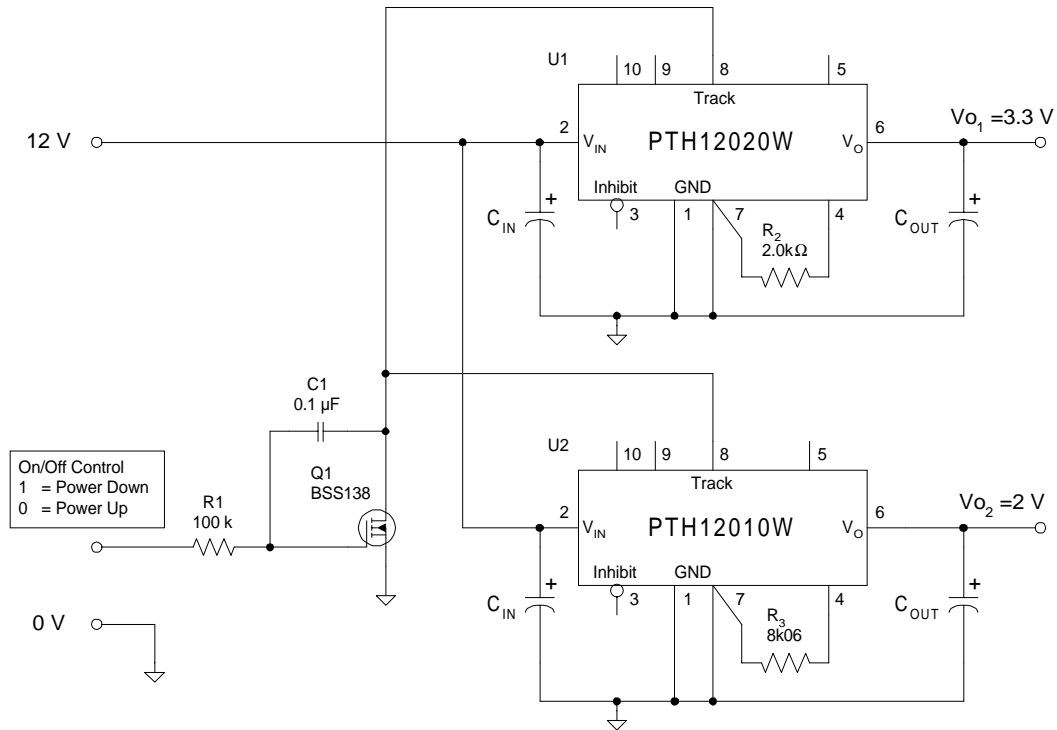

Figure 3-6; Simultaneous Power Up with Auto-Track Control

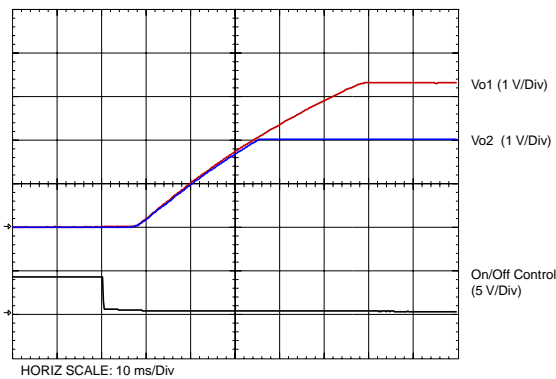
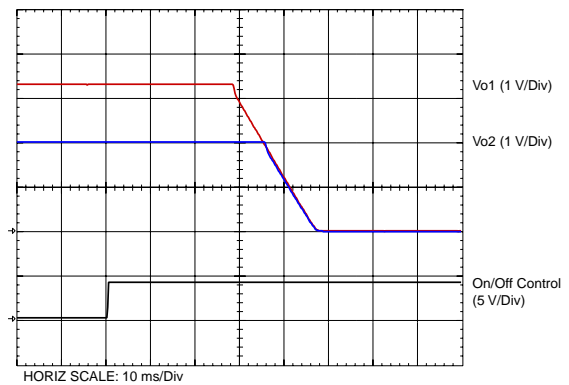

Figure 3-7; Simultaneous Power Down with Auto-Track Control



Margin Up/Down Controls

The PTH12060W, PTH12010W, PTH12020W, and PTH12030W products incorporate *Margin Up* and *Margin Down* control inputs. These controls allow the output voltage to be momentarily adjusted¹, either up or down, by a nominal 5%. This provides a convenient method for dynamically testing the operation of the load circuit over its supply margin or range. It can also be used to verify the function of supply voltage supervisors. The $\pm 5\%$ change is applied to the adjusted output voltage, as set by the external resistor, R_{SET} at the V_o Adjust pin.

The 5% adjustment is made by pulling the appropriate margin control input directly to the *GND* terminal². A low-leakage open-drain device, such as an n-channel MOSFET or p-channel JFET is recommended for this purpose³. Adjustments of less than 5% can also be accommodated by adding series resistors to the control inputs. The value of the resistor can be selected from Table 3-2, or calculated using the following formula.

Up/Down Adjust Resistance Calculation

To reduce the margin adjustment to something less than 5%, series resistors are required (See R_D and R_U in Figure 3-8). For the same amount of adjustment, the resistor value calculated for R_U and R_D will be the same. The formulas is as follows.

$$R_U \text{ or } R_D = \frac{499}{\Delta\%} - 99.8 \quad \text{k}\Omega$$

Where $\Delta\%$ = The desired amount of margin adjust in percent.

Notes:

1. The *Margin Up** and *Margin Dn** controls were not intended to be activated simultaneously. If they are their affects on the output voltage may not completely cancel, resulting in the possibility of a slightly higher error in the output voltage set point.
2. The ground reference should be a direct connection to the module *GND* at pin 7 (pin 1 for the PTHxx050). This will produce a more accurate adjustment at the load circuit terminals. The transistors Q_1 and Q_2 should be located close to the regulator.
3. The Margin Up and Margin Dn control inputs are not compatible with devices that source voltage. This includes TTL logic. These are analog inputs and should only be controlled with a true open-drain device (preferably a discrete MOSFET transistor). The device selected should have low off-state leakage current. Each input sources 8 μ A when grounded, and has an open-circuit voltage of 0.8 V.

Table 3-2; Margin Up/Down Resistor Values

% Adjust	R_U / R_D
5	0.0 k Ω
4	24.9 k Ω
3	66.5 k Ω
2	150.0 k Ω
1	397.0 k Ω

Figure 3-8; Margin Up/Down Application Schematic

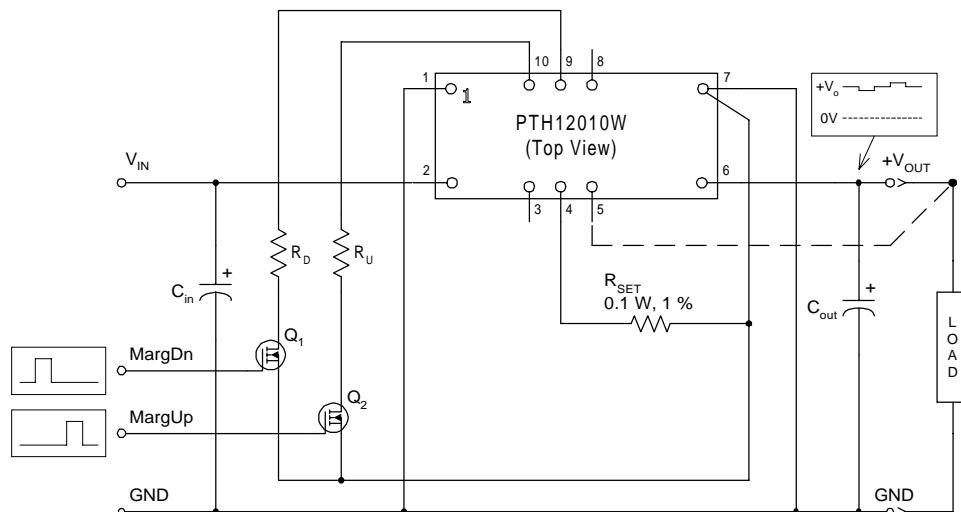

Remote Sense

The PTH12060W, PTH12010W, PTH12020W, and PTH12030W products incorporate an output voltage sense pin, V_o Sense. The V_o Sense pin should be connected to V_{out} at the load circuit (see data sheet standard application). A remote sense improves the load regulation performance of the module by allowing it to compensate for any 'IR' voltage drop between itself and the load. An IR drop is caused by the high output current flowing through the small amount of pin and trace resistance. Use of the remote sense is optional. If not used, the V_o Sense pin can be left open-circuit. An internal low-value resistor (15- Ω or less) is connected between the V_o Sense and V_{out} . This ensures the output voltage remains in regulation.

With the sense pin connected, the difference between the voltage measured directly between the V_{out} and GND pins, and that measured from V_o Sense to GND , is the amount of IR drop being compensated by the regulator. This should be limited to a maximum of 0.3 V.

Note: The remote sense feature is not designed to compensate for the forward drop of non-linear or frequency dependent components that may be placed in series with the converter output. Examples include OR-ing diodes, filter inductors, ferrite beads, and fuses. When these components are enclosed by the remote sense connection they are effectively placed inside the regulation control loop, which can adversely affect the stability of the regulator.

PACKAGING INFORMATION

Orderable Device	Status ⁽¹⁾	Package Type	Package Drawing	Pins	Package Qty	Eco Plan ⁽²⁾	Lead/Ball Finish	MSL Peak Temp ⁽³⁾
PTH12050LAH	ACTIVE	DIP MOD ULE	EUU	6	56	TBD	Call TI	Level-1-235C-UNLIM
PTH12050LAS	ACTIVE	DIP MOD ULE	EUV	6	56	TBD	Call TI	Level-1-235C-UNLIM
PTH12050LAST	ACTIVE	DIP MOD ULE	EUV	6	250	TBD	Call TI	Level-1-235C-UNLIM
PTH12050LAZ	ACTIVE	DIP MOD ULE	EUV	6	56	Pb-Free (RoHS)	Call TI	Level-3-260C-168 HR
PTH12050LAZT	ACTIVE	DIP MOD ULE	EUV	6	250	Pb-Free (RoHS)	Call TI	Level-3-260C-168 HR
PTH12050WAH	ACTIVE	DIP MOD ULE	EUU	6	56	TBD	Call TI	Level-1-235C-UNLIM
PTH12050WAS	ACTIVE	DIP MOD ULE	EUV	6	56	TBD	Call TI	Level-1-235C-UNLIM
PTH12050WAST	ACTIVE	DIP MOD ULE	EUV	6	250	TBD	Call TI	Level-1-235C-UNLIM
PTH12050WAZ	ACTIVE	DIP MOD ULE	EUV	6	56	Pb-Free (RoHS)	Call TI	Level-3-260C-168 HR
PTH12050WAZT	ACTIVE	DIP MOD ULE	EUV	6	250	Pb-Free (RoHS)	Call TI	Level-3-260C-168 HR

⁽¹⁾ The marketing status values are defined as follows:

ACTIVE: Product device recommended for new designs.

LIFEBUY: TI has announced that the device will be discontinued, and a lifetime-buy period is in effect.

NRND: Not recommended for new designs. Device is in production to support existing customers, but TI does not recommend using this part in a new design.

PREVIEW: Device has been announced but is not in production. Samples may or may not be available.

OBSELETE: TI has discontinued the production of the device.

⁽²⁾ Eco Plan - The planned eco-friendly classification: Pb-Free (RoHS) or Green (RoHS & no Sb/Br) - please check <http://www.ti.com/productcontent> for the latest availability information and additional product content details.

TBD: The Pb-Free/Green conversion plan has not been defined.

Pb-Free (RoHS): TI's terms "Lead-Free" or "Pb-Free" mean semiconductor products that are compatible with the current RoHS requirements for all 6 substances, including the requirement that lead not exceed 0.1% by weight in homogeneous materials. Where designed to be soldered at high temperatures, TI Pb-Free products are suitable for use in specified lead-free processes.

Green (RoHS & no Sb/Br): TI defines "Green" to mean Pb-Free (RoHS compatible), and free of Bromine (Br) and Antimony (Sb) based flame retardants (Br or Sb do not exceed 0.1% by weight in homogeneous material)

⁽³⁾ MSL, Peak Temp. -- The Moisture Sensitivity Level rating according to the JEDEC industry standard classifications, and peak solder temperature.

Important Information and Disclaimer:The information provided on this page represents TI's knowledge and belief as of the date that it is provided. TI bases its knowledge and belief on information provided by third parties, and makes no representation or warranty as to the accuracy of such information. Efforts are underway to better integrate information from third parties. TI has taken and continues to take reasonable steps to provide representative and accurate information but may not have conducted destructive testing or chemical analysis on incoming materials and chemicals. TI and TI suppliers consider certain information to be proprietary, and thus CAS numbers and other limited information may not be available for release.

In no event shall TI's liability arising out of such information exceed the total purchase price of the TI part(s) at issue in this document sold by TI to Customer on an annual basis.

IMPORTANT NOTICE

Texas Instruments Incorporated and its subsidiaries (TI) reserve the right to make corrections, modifications, enhancements, improvements, and other changes to its products and services at any time and to discontinue any product or service without notice. Customers should obtain the latest relevant information before placing orders and should verify that such information is current and complete. All products are sold subject to TI's terms and conditions of sale supplied at the time of order acknowledgment.

TI warrants performance of its hardware products to the specifications applicable at the time of sale in accordance with TI's standard warranty. Testing and other quality control techniques are used to the extent TI deems necessary to support this warranty. Except where mandated by government requirements, testing of all parameters of each product is not necessarily performed.

TI assumes no liability for applications assistance or customer product design. Customers are responsible for their products and applications using TI components. To minimize the risks associated with customer products and applications, customers should provide adequate design and operating safeguards.

TI does not warrant or represent that any license, either express or implied, is granted under any TI patent right, copyright, mask work right, or other TI intellectual property right relating to any combination, machine, or process in which TI products or services are used. Information published by TI regarding third-party products or services does not constitute a license from TI to use such products or services or a warranty or endorsement thereof. Use of such information may require a license from a third party under the patents or other intellectual property of the third party, or a license from TI under the patents or other intellectual property of TI.

Reproduction of information in TI data books or data sheets is permissible only if reproduction is without alteration and is accompanied by all associated warranties, conditions, limitations, and notices. Reproduction of this information with alteration is an unfair and deceptive business practice. TI is not responsible or liable for such altered documentation.

Resale of TI products or services with statements different from or beyond the parameters stated by TI for that product or service voids all express and any implied warranties for the associated TI product or service and is an unfair and deceptive business practice. TI is not responsible or liable for any such statements.

Following are URLs where you can obtain information on other Texas Instruments products and application solutions:

Products		Applications	
Amplifiers	amplifier.ti.com	Audio	www.ti.com/audio
Data Converters	dataconverter.ti.com	Automotive	www.ti.com/automotive
DSP	dsp.ti.com	Broadband	www.ti.com/broadband
Interface	interface.ti.com	Digital Control	www.ti.com/digitalcontrol
Logic	logic.ti.com	Military	www.ti.com/military
Power Mgmt	power.ti.com	Optical Networking	www.ti.com/opticalnetwork
Microcontrollers	microcontroller.ti.com	Security	www.ti.com/security
		Telephony	www.ti.com/telephony
		Video & Imaging	www.ti.com/video
		Wireless	www.ti.com/wireless

Mailing Address: Texas Instruments
Post Office Box 655303 Dallas, Texas 75265