

TECHNICAL DATA

MQ-135 GAS SENSOR

FEATURES

Wide detecting scope
Stable and long life

Fast response and High sensitivity
Simple drive circuit

APPLICATION

They are used in air quality control equipments for buildings/offices, are suitable for detecting of NH₃,NO_x, alcohol, Benzene, smoke,CO₂,etc.

SPECIFICATIONS

A. Standard work condition

Symbol	Parameter name	Technical condition	Remarks
V _c	Circuit voltage	5V±0.1	AC OR DC
V _H	Heating voltage	5V±0.1	AC OR DC
R _L	Load resistance	can adjust	
R _H	Heater resistance	33Ω ±5%	Room Tem
P _H	Heating consumption	less than 800mw	

B. Environment condition

Symbol	Parameter name	Technical condition	Remarks
Tao	Using Tem	-10℃...+45℃	
Tas	Storage Tem	-20℃...+70℃	
R _H	Related humidity	less than 95% Rh	
O ₂	Oxygen concentration	21%(standard condition)Oxygen concentration can affect sensitivity	minimum value is over 2%

C. Sensitivity characteristic

Symbol	Parameter name	Technical parameter	Remark 2
R _s	Sensing Resistance	30KΩ -200KΩ (100ppm NH ₃)	Detecting concentration scope : 10ppm-300ppm NH ₃ 10ppm-1000ppm Benzene 10ppm-300ppm Alcohol
α (200/50) NH ₃	Concentration Slope rate	≤ 0.65	
Standard Detecting Condition	Temp: 20℃ ±2℃ Humidity: 65%±5%	V _c :5V±0.1 V _h : 5V±0.1	
Preheat time	Over 24 hour		

D. Structure and configuration, basic measuring circuit

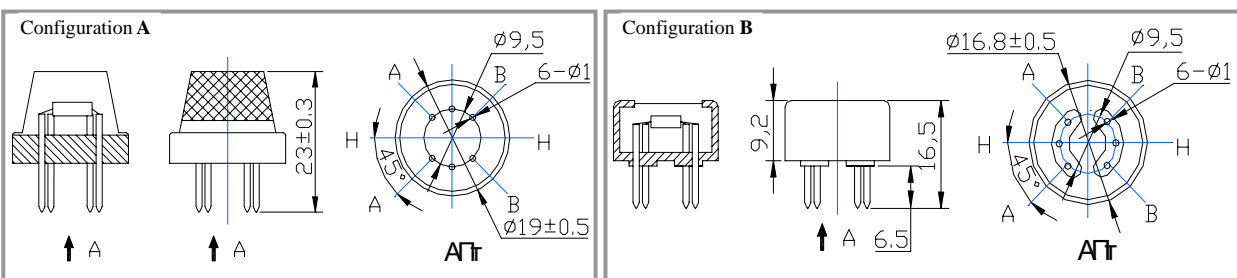
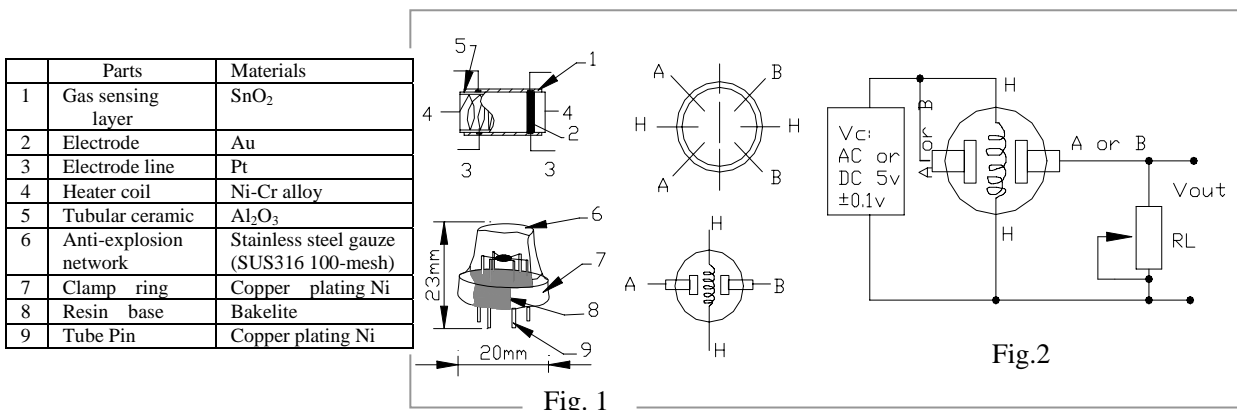

Structure and configuration of MQ-135 gas sensor is shown as Fig. 1 (Configuration A or B), sensor composed by micro Al₂O₃ ceramic tube, Tin Dioxide (SnO₂) sensitive layer, measuring electrode and heater are fixed into a crust made by plastic and stainless steel net. The heater provides necessary work conditions for work of

sensitive components. The enveloped MQ-135 have 6 pins ,4 of them are used to fetch signals, and other 2 are used for providing heating current.

Electric parameter measurement circuit is shown as Fig.2

E. Sensitivity characteristic curve

Fig.2 sensitivity characteristics of the MQ-135

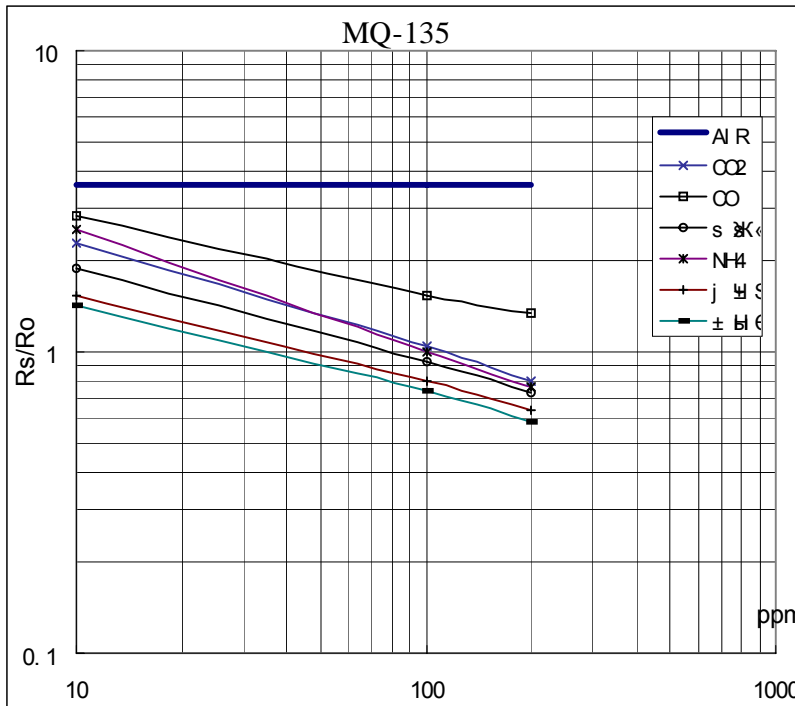

Fig.3 is shows the typical sensitivity characteristics of the MQ-135 for several gases.

in their: Temp: 20°C、
Humidity: 65%、
O₂ concentration 21%
RL=20kΩ

Ro: sensor resistance at 100ppm of NH₃ in the clean air.

Rs: sensor resistance at various concentrations of gases.

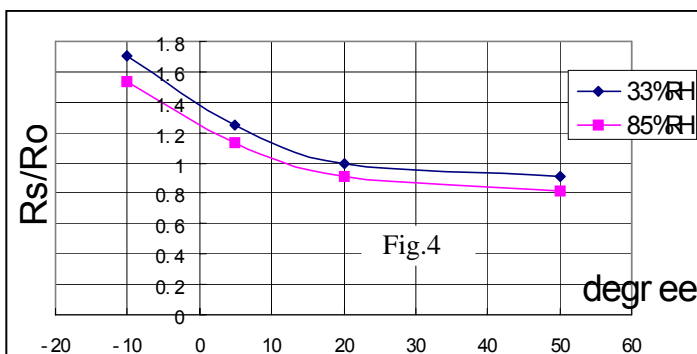

Fig.4 is shows the typical dependence of the MQ-135 on temperature and humidity.

Ro: sensor resistance at 100ppm of NH₃ in air at 33%RH and 20 degree.

Rs: sensor resistance at 100ppm of NH₃ at different temperatures and humidities.

SENSITIVITY ADJUSTMENT

Resistance value of MQ-135 is difference to various kinds and various concentration gases. So,When using this components, sensitivity adjustment is very necessary. we recommend that you calibrate the detector for 100ppm NH₃ or 50ppm Alcohol concentration in air and use value of Load resistance that(R_L) about 20 KΩ (10KΩ to 47 KΩ).

When accurately measuring, the proper alarm point for the gas detector should be determined after considering the temperature and humidity influence.

